

# Weld X Flange Connection

## Series US Weld X Flange Carbon Steel

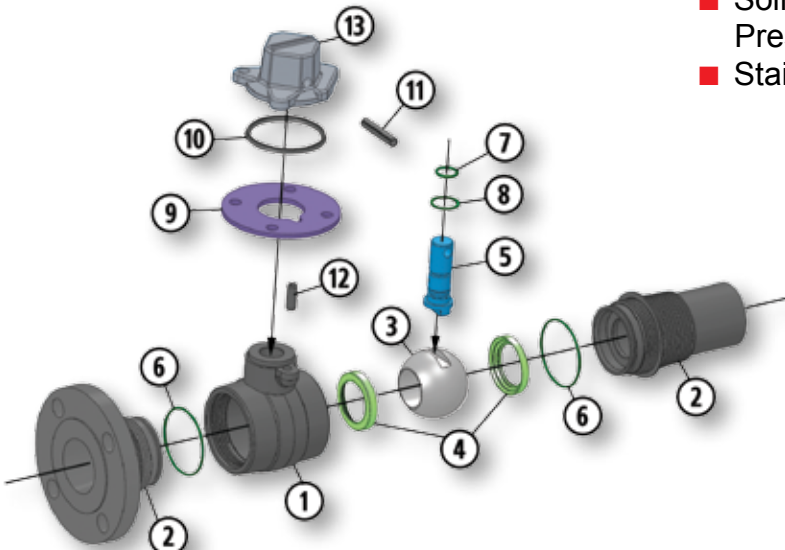

- Weld X Flange Ball Valve
- ANSI Class 150 (285 PSI WP)
- ANSI Class 300 (740 PSI WP)
- 2" Through 4"
- Multi-Seal Seats
- True Full Port for Hot Tap Service
- Heat Dissipating Fins for Protection of Seats and Seals During Welding
- Rugged Stainless Steel Lock Plate
- Heavy Duty Forged Steel Components
- Solid Balls for Reduction of Turbulence and Pressure Drop
- Stainless Steel Stem Standard



\* Note: Valve is seal welded and is not field repairable.

### Material Description

ITEM	PART NAME	MATERIAL (STANDARD)
1	Body	ASTM A105
2	Adapter	ASTM A105
3	Ball	Carbon Steel - Nickel Chrome Plated
4	Seats	Nylon
5	Stem	316 Stainless Steel
6	Body O-Ring	Buna-N
7	Stem O-Ring	Buna-N
8	Stem Seal	TFE
9	Lock Plate	Stainless Steel
10	Weather Seal	Polyethylene
11	Roll Pin	Stainless Steel
12	Stop Pin	Stainless Steel
13	Drive Nut - 2" Square	Ductile Iron

### Dimensional Data

SIZE	CATALOG	PORT/A	WP	B	C	D	E	F	G	LBS.	Cv
2x1.5x2	2R-US13-WF	1.5	285	9.4	5.9	5	6	2	4.5	20	148
2x1.5x2	2R-US33-WF	1.5	740	10.15	5.9	5	6.50	2	4.5	23	148
2x2x2	2F-US13-WF	2	285	10	5.9	5.50	6	2	4.5	28	-
2x2x2	2F-US33-WF	2	740	10.2	5.9	5.50	6.50	2	4.5	28	-
3x3x3	3F-US13-WF	3	285	11.3	5.9	6.75	7.5	2	4.5	53	-
3x3x3	3F-US33-WF	3	740	11.5	5.9	6.75	8.25	2	4.5	56	-
4x3x4	4R-US13-WF	3	285	10.9	6.4	6.75	9	2	4.5	60	662
4x3x4	4R-US33-WF	3	740	12.4	6.4	6.75	10	2	4.5	70	662
4x4x4	4F-US13-WF	4	285	12.1	6.4	7.50	9	2	4.5	81	-
4x4x4	4F-US33-WF	4	740	12.4	6.4	7.50	10	2	4.5	91	-

