

P289 1" Parts

Item	Description	Qty.	Part Number
1	Adjusting Screw, Plated Steel	1	648-487-000
2	Hex Nut, Plated Steel	1	634-154-000
3	Spring Guide, plated steel	1	626-079-000
4	Spring	1	1-4.5 PSIG (0.1-0.3 BAR), Pink
			4-15 PSIG (0.3-1 BAR), Red
			10-20 PSIG (0.7-1.4 BAR), Silver
			15-50 PSIG (1-3.4 BAR), & 45-75 PSIG (3.1-5.2 BAR), Green
5	Piston Retainer, Plated Steel	1	643-191-000
6	Piston, Plated Steel (All Output Pressures other than 45-75 PSIG)	1	637-306-000
			Range 45-75 PSIG
7	Diaphragm	1	P289 1" Nitrile
			P289 1" Fluoroelastomer
8	Stem Guide Assembly	1	814-014-000
9	Pipe Plug, Plated Steel	1	639-099-000
10	Spacer Tube, Stainless Steel	1	654-178-000
11	O-ring	2	Nitrile
			Fluoroelastomer
12	Pitot Tube, Aluminum	1	660-051-000
13	Retaining Ring, plated steel	1	644-051-000
14	Screen, Stainless Steel	1	647-018-000
15	Gasket, Neoprene	1	624-063-000
16	Body, Aluminum, 1" NPT	1	664-295-000
			Body, Aluminum, 3/4" x 1" NPT
17	O-ring	1	Nitrile
			Fluoroelastomer
18	O-ring Spacer, Aluminum	1	654-177-000
19	O-ring Piston, Aluminum	1	637-311-000
20	Machine Screw, Stainless Steel	2	648-488-000
21	Gasket, Composite	2	624-062-000
22	Machine Screw	8	648-466-005
23	Washer, Steel	1	662-204-000
24	Hex Nut, Plated Steel	1	634-162-000
25	Bonnet, Aluminum	1	604-221-000

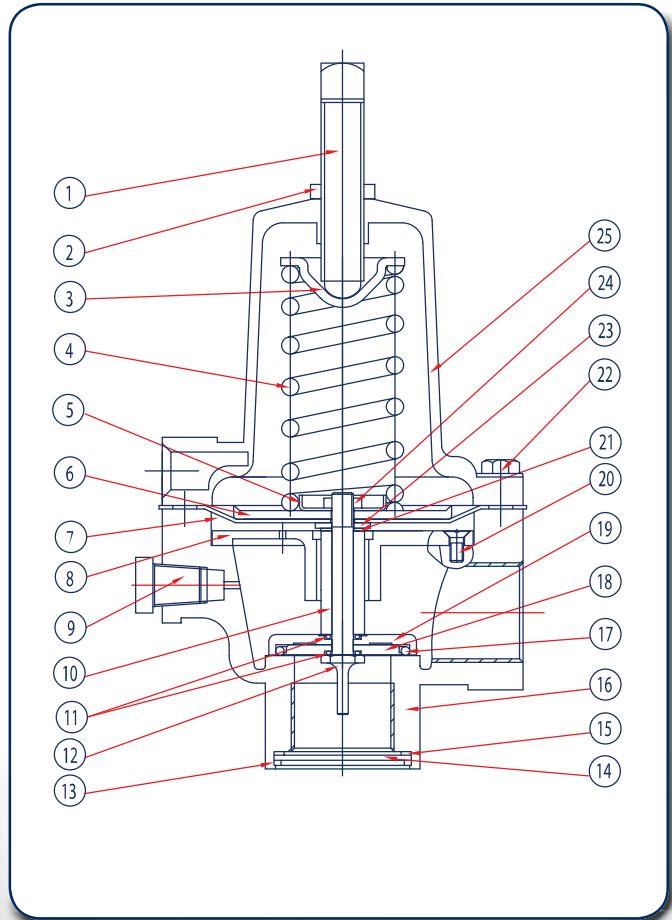

P289 1" Dimensions

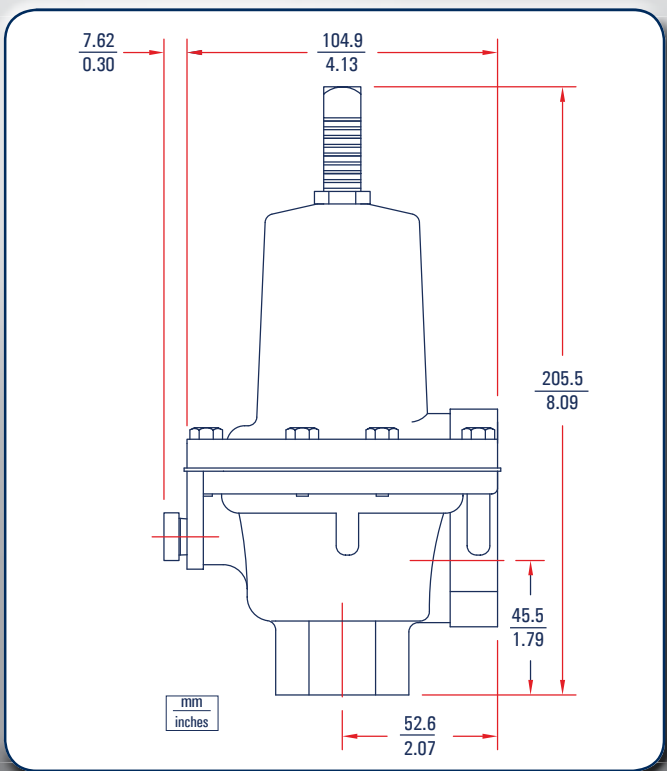

P289 1" & 3/4" x 1" Regulator Rebuild Kits

	Kit Includes	Part Number
P289 1"	Nitrile Diaphragms, Screen & Gasket	971-289-000
P289 1"	Fluorocarbon Diaphragm, Screen & Gasket	971-289-001



L289 & P289 2" Parts

Item	Description	Qty.	Part Number
1	Gasket, Neoprene	1	624-066-000
2	Screen, Stainless Steel	1	647-020-000
3	Seat Gasket, Neoprene	1	624-071-000
4	Main Seat	Brass	650-132-000
		Stainless Steel	650-133-000
5	O-ring	Nitrile	649-302-000
		Fluoroelastomer	649-301-000
6	O-ring, Washer, Stainless Steel	1	662-207-000
7	Stem Guide Assembly, Cast Iron & Brass	1	814-015-000
8	Upper Pipe Plug	1	639-102-000
9	Diaphragm Head, Plated Steel	1	637-315-000
10	Lower Spring Retainer, Zinc Plated Steel	1	643-197-000
11	Spring	5 to 10" W.C.	655-732-000
		7 to 18" W.C. , Dark Blue	655-691-000
		12 to 40" W.C. , White	655-767-000
		0.5 to 2.25 PSIG (.03 to .15 BAR), Grey	655-692-000
		1.75 to 7 PSIG (.12 to .48 BAR), Dark Green	655-693-000
	4 to 10 PSIG (.27 to .69 BAR), Red Stripe	655-694-000	
12	Bonnet, Aluminum	1	604-558-000
13	Closing Cap Gasket, Neoprene	1	624-069-000
14	Closing Cap, Acetal	1	610-056-000
15	Adjusting Screw, Zinc	1	648-499-000
16	Upper Spring Seat Washer, Aluminum	1	662-206-000
17	Hex Nut, Plated Steel	1	634-173-000
18	Pitot Tube	Brass	660-053-000
		Stainless Steel	660-054-000
19	Machine Bolt, Stainless Steel	8	648-466-000
20	Diaphragm	Nitrile	618-071-000
		Fluoroelastomer	618-071-001
21	Machine Screw, Stainless Steel	4	648-500-000
22	Low Pipe Plug, Plated Steel	1	639-099-000
23	Snap Washer, Plated Steel	1	662-208-000
24	Spacer	Brass	654-181-000
		Stainless Steel	654-182-000
25	Gasket, Neoprene	3	624-065-000
26	Body	3/4" x 2" Aluminum (L289)	624-303-000
		1" x 2" Aluminum (L289)	624-303-001
		2" x 2" Aluminum (L289)	624-303-002
		2" x 2" Iron (P289)	664-302-000
27	Retaining Ring, Plated Steel	1	644-054-000

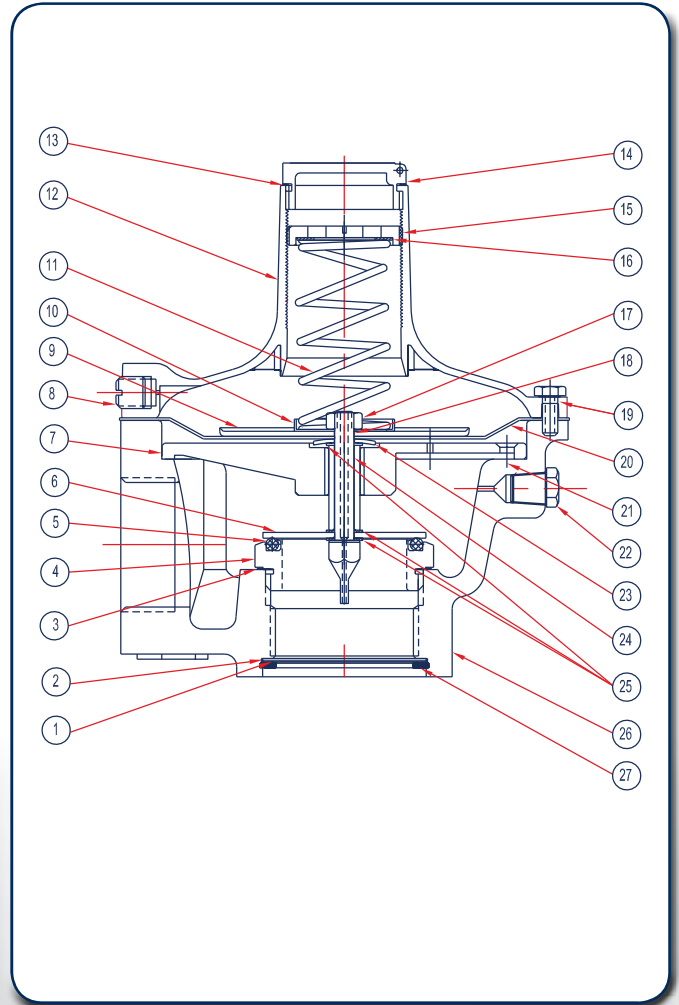

P289 2" Dimensions

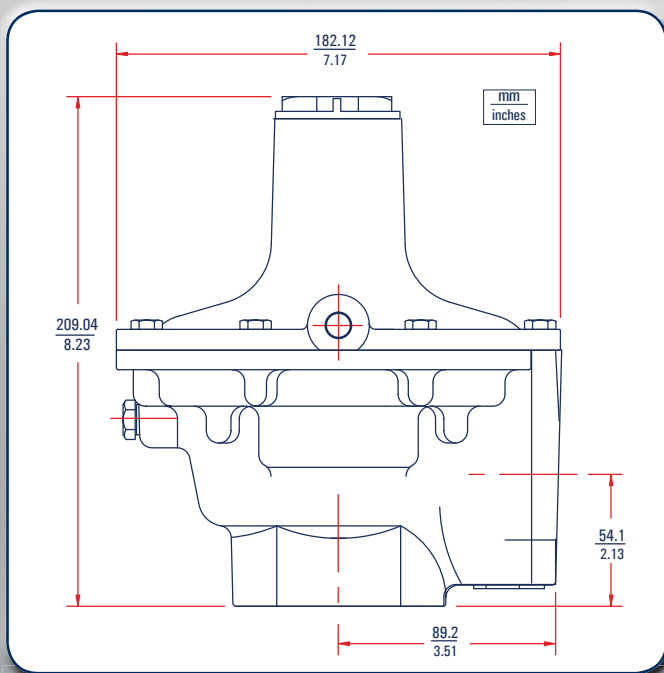

P289 2" Regulator Rebuild Kits

	Kit Includes	Part Number
P289 2"	Nitrile Diaphragms, Screen, Screen Gasket (Neoprene), Composite Gaskets (Qty.3)	971-289-002
P289 2"	Fluorocarbon Diaphragm, Screen, Screen Gasket (Neoprene), Composite Gaskets (Qty. 3)	971-289-003



L289 & P289 Flow Rates

