

NUFLO™

Liquid Turbine Flowmeters

Accurate Flow Measurement



NuFlo developed its first flowmeter for oilfield applications in 1957. The meter incorporated a tungsten-carbide shaft and bearing to withstand the rugged conditions of the oilfield environment. Over the years, this flowmeter has built an unsurpassed reputation for withstanding severe punishment while maintaining operational and measurement integrity.

NuFlo turbine flowmeters indicate flow rate and measure total throughput of a liquid line. As liquid flows through the meter and over the rotor, the rotor turns at a speed that is directly proportional to the flow rate. A magnetic pickup senses the rotor blades as they pass and generates an electrical (sine wave) signal. These electrical pulses are then transmitted to the flow measurement readout equipment.

First Class Design Delivers First Class Performance

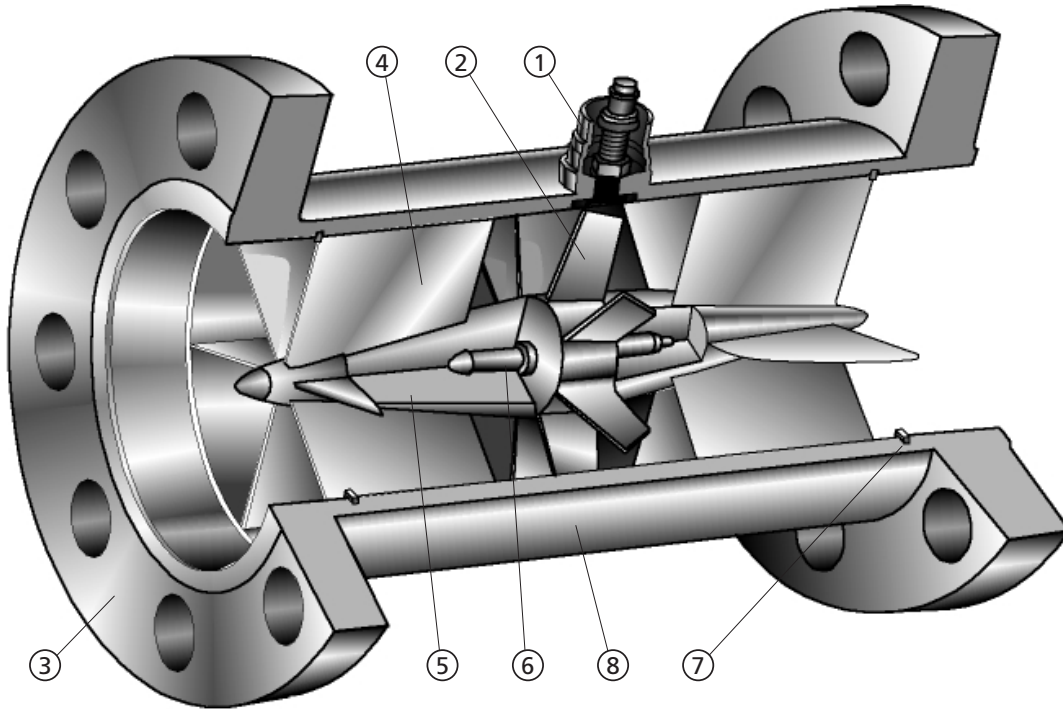

1. Permanent conduit connection is standard.
2. ROTOR is pitched and pre-calibrated to determine accuracy.
3. END CONNECTIONS available, flanged or threaded, standard or special.
4. FLOW VANES increase performance at low rates.
5. FLOW VANE HUB supports rotor assembly.
6. ROTOR SHAFT, BEARINGS, AND THRUST BALL are made of tungsten carbide for long service without lubrication other than by the liquid being measured.
7. RETAINING RINGS make disassembly easy.
8. FLOWMETER BODY is sturdy, one-piece construction, precision finished.

Applications

NuFlo offers turbine flowmeters in a variety of end connections and accuracy levels. Typical applications are:

- Water-injection measurement
- Heater treaters
- Test and production separators
- Disposal wells
- CO₂ injection
- Steam generator fuel and feed water
- Metering liquid fertilizer
- Water, fuel, and chemical measurement in plant settings
- Chemical tank loading and unloading
- Measuring liquid propane
- Insitu mining and leaching

Accuracy

NuFlo meters are classified as Standard Grade and Industrial Grade, based on the linearity of the meter. The Standard Grade meter provides a cost-effective measurement solution

for applications where higher accuracy is not required. For higher accuracy applications, an Industrial Grade meter can be used. Such meters can achieve even greater accuracy if the range of the flow through the meter is specified.

Meter Grade	Linearity	Repeatability
Standard*	± 1% of reading	± 0.05%
Industrial*	± 0.5% of reading	± 0.02%
Enhanced accuracy	Consult factory	Consult factory

* For 3/8 in. meters, linearity is ± 2% of reading (standard) and ± 1% of reading (industrial).

Temperature Range (magnetic pickup)

	Temperature Range		Flowmeter Size
Standard	-67 to 225°F	-55 to 107°C	3/8 in. through 3/4 in.
Standard	-67 to 250°F	-55 to 121°C	7/8 in. through 8 in.
Medium	-67 to 450°F	-55 to 232°C	all sizes

Note: Consult NuFlo Measurement Systems for any use of turbine flowmeters above 450°F (232°C).

Compliances

- CSA Certified Hazardous Locations Class I, Group A,B,C,D, Div. 1
- NACE MR01-75 (NACE traceability available on pressure containing components - on request)
- EZ-IN® meters and 1502 WECO® union meters available with CE mark for Pressure Equipment Directive (PED, 97/23/EC)

Materials of Construction

- Meter Body & Vanes Grade 316L stainless steel
- Rotor CD-4MCu
- Shaft & Bearings Tungsten Carbide

Optional Materials

- Shaft Binderless carbide for enhanced corrosion resistance to selected chemicals
- Shaft & Bearings Silver brazing to withstand temperatures to 550°F and chemicals that attack epoxy bonding bearing materials
- Rotor Nickel plating for enhanced corrosion resistance to selected chemicals (especially acids that corrode ferrous materials)

Benefits

- More accurate and repeatable measurement
- An economical solution for turbine flowmeter applications
- Easy installation and a variety of end connections
- Minimum maintenance required
- Long service life even in severe applications

Meter Size Selection

Flowmeter size selection should be based on the instantaneous flow rate of the line into which the meter will be mounted. Meter size should never be based on the nominal piping size of the installation. Refer to Linear Flow Range Chart for meter size selection. The meter will remain accurate at flow rates higher than its rating, but bearing wear and pressure drop across the meter can shorten the life span of the meter. NuFlo flowmeters can be over-ranged by 10% for short periods without damage.

Installation

- The meter should be installed with the arrow on the meter body corresponding to flow direction of the line.
- A 10-diameter length of straight unrestricted pipe must be upstream and a 5-diameter length of straight unrestricted pipe must be downstream of the flowmeter. Both pipe sections should be the same nominal pipe size as the flowmeter's end connection.
- Throttling/Control valves should be located downstream of the flowmeter.

Linear Flow Range ^(1, 2, 3)

Flow-meter size (3)	mm	GPM	m ³ /HR	BPD	Nominal (2) Calibration Factor		Maximum Output Frequency (Pulses/Sec)	ΔP at Maximum Flow (2)	
					Pulses Gallon	Pulses x 1000/m ³		psi	kPa
3/8	10	0.3 - 3	0.068 - 0.68	10 - 100	22000	(5812)	1100	4.0	28
1/2	13	0.75 - 7.5	0.17 - 1.70	25 - 250	14500	(3830)	1815	12.0	83
3/4	19	2 - 15	0.45 - 3.41	68 - 515	2950	(780)	740	18.0	124
7/8	22	3 - 30	0.68 - 6.81	100 - 1000	2350	(621)	1175	20.0	138
1	25	5 - 50	1.14 - 11.36	170 - 1700	900	(238)	750	20.0	138
1-1/2	38	15 - 180	3.41 - 40.88	515 - 6000	325	(86)	975	16.0	110
2	51	40 - 400	9.09 - 90.85	1300 - 13000	55	(14.5)	365	22.0	152
3	76	80 - 800	18.16 - 181.66	2750 - 27500	57	(15.2)	760	20.0	138
4	102	100 - 1200	22.71 - 272.55	3400 - 41000	30	(7.9)	600	10.0	69
6	152	250 - 2500	56.78 - 567.82	8600 - 86000	7	(1.8)	290	10.0	6
8	203	350 - 3500	79.49 - 794.94	12000 - 120000	3	(.8)	175	6.0	41

1. The linear flow range of liquids with non-lubricating characteristics is limited to the upper 60% of rating.

2. Based on water.

3. Consult NuFlo Measurement Systems for engineering assistance with applications involving liquids of viscosities greater than 5 centistokes on 3/8-in. through 3/4-in. meters.

Conduit Thread Data

Temperature Rating	250°F (121°C)	450°F (232°C)
Thread Size	1" NPT	1" NPT

Note: Consult NuFlo Measurement Systems for any use of turbine flowmeters above 450°F (232°C).

End Connections

NuFlo flowmeters are available in a variety of end connections:

- threaded
- grooved
- flanged
- EZ-IN®
- WECO® 1502

Threaded (NPT) End Connection

- Threaded meter sizes range from 3/8-in. to 2-in.
- Meter sizes from 3/8-in. to 1-in. pipe all have 1-in. NPT end connections to simplify meter size changes.
- All meter sizes other than the 2-in. have male threads.

Flowmeter Size x End Connection Size	Length		Working Pressure	
	in.	mm	psi	MPa
3/8 x 1 in.	4.0	102	7500	51.71
1/2 x 1 in.	4.0	102	7500	51.71
3/4 x 1 in.	4.0	102	7500	51.71
7/8 x 1 in.	4.0	102	5000	34.48
1 x 1 in.	4.0	102	5000	34.48
1-1/2 x 1-1/2 in.	6.0	152	5000	34.48
2 x 2 in.	10.0	254	5000	34.48

Flanged End Connection

Turbine flowmeters with flanged end connections are available in both raised-face (RF) models and ring-type joint (RTJ) models. Flanged materials can be carbon steel or stainless steel. All flanged NuFlo meters are equipped with slip-on flanges, which are then welded to the outside of the meter rather than being welded to the end of the meter body. Thus, the flange never comes into contact with the fluid being measured.

Flowmeter Size x End Connection Size	Length	
	in.	mm
3/8 x 1/2 in.*	5.0	127.0
1/2 x 1/2 in.*	5.0	127.0
3/4 x 3/4 in.*	5.0	127.0
7/8 x 1 in.	6.0	152.4
1 x 1 in.	6.0	152.4
1-1/2 x 1-1/2 in.	7.0	177.8
2 x 2 in.	8.5	215.9
3 x 3 in.**	10.0	254.0
4 x 4 in.	12.0	304.8
6 x 6 in.***	12.0	304.8
8 x 8 in.***	12.0	304.8

* 3/8 in. through 3/4 in. 900#, 1500#, 2500# is 6-1/4 in. (158.8 mm)

** 3 in. 2500# is 12 in. (304.8 mm)

*** 6 in. and 8 in. 2500# is 14 in. (355.6 mm)

ANSI B16.5 Pressure Rating

CS = Carbon Steel SS = Stainless Steel

Flange Classification	150 #		300 #		600 #		900 #		1500 #		2500 #	
	CS	SS	CS	SS	CS	SS	CS	SS	CS	SS	CS	SS
Flange Material												

Design-Operating Temperature Range

Temperature Range (°F / °C)	Max Working Pressure	psi	mPa	285	275	740	720	1480	1440	2220	2160	3705	3600	6170	6000
-20 to 100° F (28.8 to 37.7° C)				1.96	1.89	5.10	4.96	10.2	9.92	15.3	14.9	25.5	24.8	42.5	41.3
-20 to 200° F (28.8 to 93.3° C)				1.79	1.62	4.65	4.27	9.31	8.54	13.9	12.8	23.2	21.3	38.8	35.5
-20 to 400° F (-28.8 to 204.4° C)				1.38	1.34	4.38	3.55	8.76	7.09	13.1	10.6	21.8	17.7	36.4	29.5
-20 to 600° F (-28.8 to 315.5° C)				0.96	0.96	3.79	3.10	7.55	6.20	11.3	9.34	18.8	15.5	31.4	25.9

Test Pressure: 1.5 times maximum working pressure at -20 to 100° F (28.8 to 37.7° C)

Grooved End Connection

Flowmeters with grooved end connections are available in 7/8-in. through 8-in. sizes.

Flowmeter Size x End Connection Size	Length		Working Pressure	
	in.	mm	psi	MPa
7/8 x 1 in.	4.0	102	1000	6.9
1 x 1 in.	4.0	102	1000	6.9
1-1/2 x 1-1/2 in.	6.0	152	1000	6.9
1-1/2 x 2 in.	6.0	152	1000	17.2
2 x 2-1/2 in.	10.0	254	1000	17.2
3 x 3 in.	12.5	318	1000	6.9
4 x 4 in.	12.0	305	1000	6.9
6 x 6 in.	12.0	305	800	5.5
8 x 8 in.	12.0	305	800	5.5

EZ-IN® End Connection

Series BF turbine flowmeters with EZ-IN connections provide a cost-effective alternative to typical flanged-meter applications. Series BF meters with EZ-IN connections offer the accuracy, rugged construction, and maintenance-free operation of conventional NuFlo flowmeters plus the following advantages:

- Lower installation cost.
- Less expensive than a conventional, flanged meter.
- Spreader nuts enable easy removal and inspection.
- The raised-face EZ-IN meter will mate to any flange rated ANSI 150# to 1500#. The ring-joint (RTJ) version will mate to ANSI 900#, 1500# or 2500# RTJ flange. Specify flange type when ordering.
- CE-marked 8 x 8-in. EZ-IN RF requires special centering rings.

WECO® 1502 Union End Connection

Flowmeters with 1502 end connections are commonly used in high-pressure oilwell service applications. Meter sizes 1", 1 1/2" and 2" have 2" union end connections, and 3" meters have 3" union end connections. All 1502 union end meters have two pickup adapters.

Flowmeter Size x End Connection Size	Length		Working Pressure	
	in.	mm	psi	MPa
1 x 2 in.	8.00	203.3	15000	103
1-1/2 x 2 in.	8.60	218.4	15000	103
2 x 2 in.	9.00	228.6	15000	103
3 x 3 in.	13.0	330.2	15000	103

WECO® is a federally registered trademark of FMC Technologies, Inc.

Specialized Flowmeters

- High-pressure
- Nitrogen
- CO₂
- Cement-slurry
- Corrosive-service
- Drilling fluids

Contact NuFlo Measurement Systems for application assistance.

Flowmeter Size x End Connection Size	Raised Face Flange Lengths, in. (mm)					
	1 in.	2 in.	3 in.	4 in.	6 in.	8 in.
3/8 x 1 in.	4.0 (102)	—	—	—	—	—
3/8 x 2 in.	—	2.5 (63.5)	—	—	—	—
1/2 x 1 in.	4.0 (102)	—	—	—	—	—
1/2 x 2 in.	—	2.5 (63.5)	—	—	—	—
3/4 x 1 in.	4.0 (102)	—	—	—	—	—
3/4 x 2 in.	—	2.5 (63.5)	—	—	—	—
7/8 x 1 in.	4.0 (102)	—	—	—	—	—
7/8 x 2 in.	—	2.5 (63.5)	—	—	—	—
1 x 1 in.	4.0 (102)	—	—	—	—	—
1 x 2 in.	—	2.5 (63.5)	—	—	—	—
1-1/2 x 2 in.	—	2.5 (63.5)	—	—	—	—
2 x 2 in.	—	2.5 (63.5)	—	—	—	—
3 x 3 in.	—	—	4.25 (108)	—	—	—
4 x 4 in.	—	—	—	5.0 (127)	—	—
6 x 6 in.	—	—	—	—	5.75 (146.1)	—
8 x 8 in.	—	—	—	—	—	6.25 (158.8)

Ring Joint Flange Lengths, in. (mm)						
	1 in.	2 in.	3 in.	4 in.	6 in.	8 in.
1 x 2 in.	—	3.5 (88.9)	—	—	—	—
1-1/2 x 2 in.	—	3.5 (88.9)	—	—	—	—
2 x 2 in.	—	3.5 (88.9)	—	—	—	—
3 x 3 in.	—	—	4.25 (108)	—	—	—
4 x 4 in.	—	—	—	5.0 (127)	—	—
6 x 6 in.	—	—	—	—	5.75 (146.1)	—
8 x 8 in.	—	—	—	—	—	6.25 (158.8)

Pressure Drop Curve for NuFlo Turbine Flowmeters

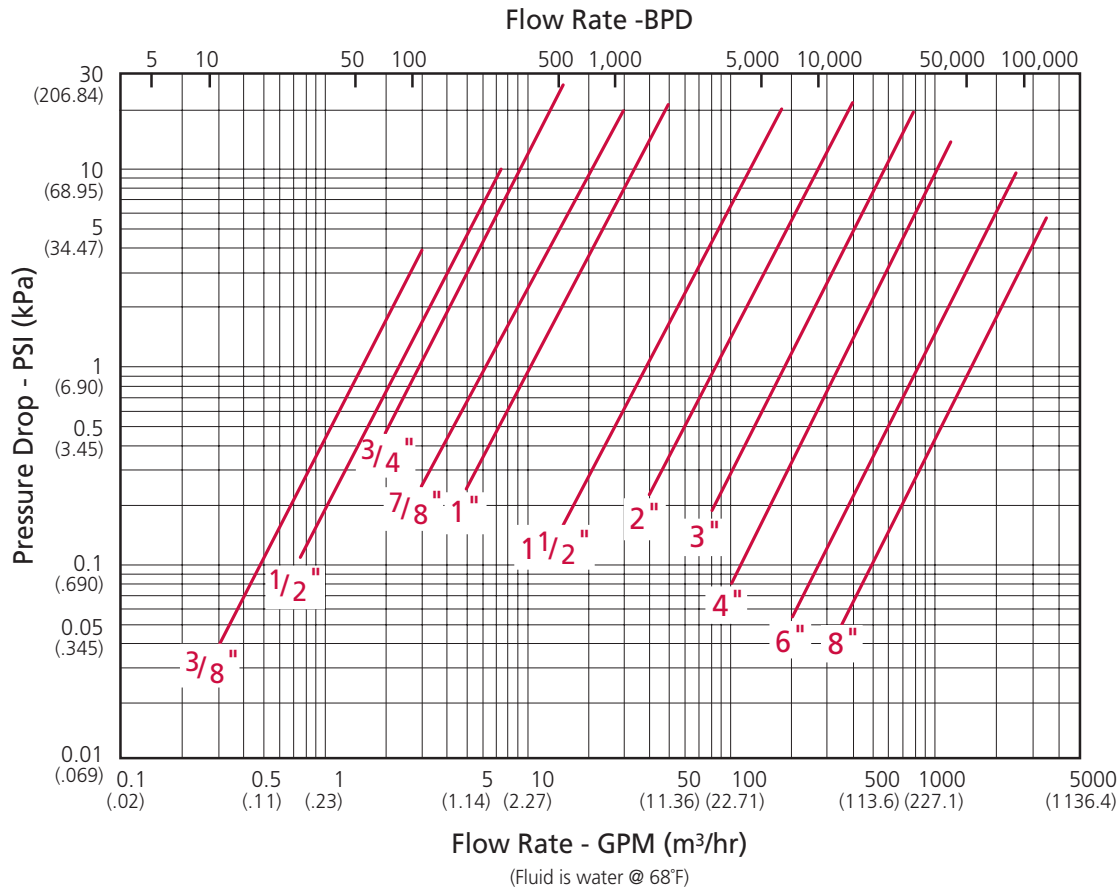

Companion readout instruments for NuFlo turbine flowmeters are also available.



MEASUREMENT SYSTEMS

Formerly: NuFlo Measurement Systems • Barton Instrument Systems • Caldon, Inc.

NORTH AMERICA
1.800.654.3760
 ms-us@c-a-m.com

ASIA PACIFIC
65.6737.0444
 ms-asiapacific@c-a-m.com

EUROPE, MIDDLE EAST & AFRICA
44.1243.826741
 ms-uk@c-a-m.com

USA: Houston, TX • Corpus Christi, TX • Kilgore, TX • Odessa, TX • Dallas, TX • Tulsa, OK
 Duncan, OK • Denver, CO • Bakersfield, CA • Shreveport, LA • Lafayette, LA
 Houma, LA • Pittsburgh, PA • Laurel, MS • Dunbar, WV • Casper, WY • Charleston, WV

CANADA: Calgary, AB • Edmonton, AB

INTERNATIONAL: Aberdeen, Scotland • Beijing, China • Bognor Regis, UK
 Dubai, UAE • Hassi Messaoud, Algeria • Kuala Lumpur, Malaysia • Singapore

HOUSTON HEAD OFFICE: 281.582.9500 • www.c-a-m.com/flo