

W627 Liquid Gas Regulator

- Wide Range of Flow Capacities
- Durable Powder Coated Exterior
- Installation Versatility
- External Pressure Registration Model

The W627 is a spring loaded, direct-operated regulator for liquid service. These regulators provide durability, from the powder-coated epoxy exterior finish, as well as installation versatility, from the multi-position body and spring case configurations. These regulators are also available in an external pressure registration model (P627M).

Applications

- Industrial Chemical Processes
- Chemical Production
- Electronic Manufacturing



Materials of Construction

Body, Bonnet, Diaphragm Case	
Stainless Steel, Steel or Iron Body, Bonnet and Diaphragm Case	
Iron Body, Bonnet and Diaphragm Case	
Steel Body, Bonnet and Diaphragm Case	
LCC Steel Body, Bonnet and Diaphragm Case	
Diaphragm	
Option	Nitrile (Low Pressure) or Neoprene (High Pressure)
Seat	
Options	Nitrile
	Nylon
	Fluorocarbon
Orifice	
Stainless Steel	

Specifications

Maximum Differential Pressure (PSIG)		
Elastomer	200	
Nylon	400	
Outlet		
10–500 PSIG		
Body Sizes		
3/4 NPT		
1 NPT		
2 NPT		
Orifice Sizes		
1/4"		
1/2"		
		Water Capacities (GPM)*
Output	Outlet Range (PSIG)	
	10–20 PSIG	2.9–43
	15–40 PSIG	6.7–45
	35–80 PSIG	6.4–70
	70–150 PSIG	9.4–73
	140–250 PSIG	10–58
	240–500 PSIG	10–66
* Capacity at 20% droop		
Temperature Range	–40° to 180° F (–40° to 82° C)	
Weight Approximate		
1"	5.3 lbs	2.39 kg
2"	8.8 lbs	3.96 kg

Maximum Bonnet and Diaphragm Casing Pressure	Spring & Diaphragm Casing Style	W627		W627M		W627H & W627HM	
		PSIG	BAR	PSIG	BAR	PSIG	BAR
Maximum pressure to spring and diaphragm casing to prevent leak to atmosphere (internal parts damage may occur).	Iron	250	17.2	250	17.2	N/A	N/A
	Steel / SS	250	17.2	250	17.2	800	55.2
Maximum pressure to spring and diaphragm casings to prevent burst of casings during abnormal operation (leak to atmosphere and internal parts may occur).	Iron	465	32.1	465	32.1	N/A	N/A
	Steel / SS	1200	82.7	1200	82.7	1200	82.7
Maximum diaphragm casing overpressure to prevent damage to internal parts.	All	60	4.1	60	4.1	120	8.3

W627 Regulator Rebuild Kits

	Kit Includes	Part Number
W627 Low Pressure	Nitrile diaphragms (2), SS Nitrile valve disk, O-rings, back-up rings, and retaining pin	971-627-N00
	Nitrile diaphragms (2), SS Nylon valve disk, O-rings, back-up rings, and retaining pin	971-627-N01
W627 High Pressure	Neoprene diaphragm, SS Nitrile valve disk, O-rings, back-up rings, retaining pin	971-627-N02
	Neoprene diaphragm, SS Nylon valve disk, O-rings, back-up rings, retaining pin	971-627-N03
	Nitrile diaphragm, SS Fluoroelastomer valve disk, O-rings, back-up rings, and retaining pin	971-627-V00

W627 Part Matrix

W627						1	
	↑	↑	↑	↑	↑	↑	Port Size
06							3/4"
08							1"
16							2"
							Spring Range
							PSIG BAR
020							10 - 20 0.69 - 1.4
040							15 - 40 1 - 2.8
080							35 - 80 2.4 - 5.5
095							10 - 95 0.7 - 6.6
150							70 - 150 4.8 - 10.3
250							140 - 250 9.7 - 17.2
500							240 - 500 16.5 - 34.5
							Special Adders
0							None
2							Monitor
A							150 #RF
B							300 #RF
C							600 #RF
D							Socket Weld
E							900 #RTJ
W							150 #RF & Monitor
X							300 #RF & Monitor
Y							600 #RF & Monitor
Z							Socket Weld & Monitor
							Version
0							Standard
							Orifice
4							1/4"
8							1/2"
							Seat Material
0							Nitrile
1							Nylon
2							Fluorocarbon
1							
							Case / Body
0							Iron / Iron
1							Steel / Steel
7							Steel / LCC Steel
9							Stainless / Stainless

NOTE: Nitrile or FKM is recommended for 5-20, 15-40 and 10-95 PSIG. Nylon is recommended for pressures above 150 PSIG.

NOTE: Nitrile or FKM is recommended for 5-20, 15-40 and 10-95 PSIG. Nylon is recommended for pressures above 150 PSIG.

Outlet Pressure Range	Outlet Pressure Setting		Inlet Pressure		3/4" (DN 20) Body Size		1" (DN 25) Body Size		2" (DN 50) Body Size	
	PSIG	BAR	PSIG	BAR	1/4 Inch (6.35 mm) Orifice	1/2 Inch (12.7 mm) Orifice	1/4 Inch (6.35 mm) Orifice	1/2 Inch (12.7 mm) Orifice	1/4 Inch (6.35 mm) Orifice	1/2 Inch (12.7 mm) Orifice
10 to 20 PSIG (0.7 to 1.4 BAR)	10	0.69	15	1.0	2.9 (11.0)	6.9 (26.1)	2.9 (11.0)	7.0 (26.5)	3.0 (11.4)	7.0 (26.5)
			20	1.4	4.0 (15.1)	8.7 (32.9)	4.0 (15.1)	9.2 (34.8)	4.1 (15.5)	9.2 (34.8)
			30	2.1	5.4 (20.4)	13 (49.2)	6.0 (22.7)	13 (49.2)	6.0 (22.7)	13 (49.2)
			60	4.1	8.3 (31.4)	12 (45.4)	9.2 (34.8)	23 (87.1)	9.2 (34.8)	28 (106)
			75	5.2	9.4 (35.6)	12 (45.4)	10 (37.9)	23 (87.1)	10 (37.9)	33 (125)
			100	6.9	10 (37.9)	11 (41.6)	12 (45.4)	23 (87.1)	12 (45.4)	38 (144)
			150	10.3	10 (37.9)	10 (37.9)	15 (56.8)	22 (83.3)	15 (56.8)	29 (110)
			200	13.8	10 (37.9)	10 (37.9)	18 (68.1)	20 (75.7)	18 (68.1)	24 (90.8)
	300	20.7	10 (37.9)	-	22 (83.3)	-	22 (83.3)	-		
	400	27.6	10 (37.9)	-	25 (94.6)	-	25 (94.6)	-		
	20	1.4	30	2.1	4.8 (18.2)	11 (41.6)	4.8 (18.2)	11 (41.6)	4.8 (18.2)	11 (41.6)
			50	3.4	7.4 (28.0)	14 (53.0)	7.4 (28.0)	20 (75.7)	7.4 (28.0)	20 (75.7)
			60	4.1	8.4 (31.8)	14 (53.0)	8.4 (31.8)	25 (94.6)	8.4 (31.8)	25 (94.6)
			100	6.9	12 (45.4)	17 (64.3)	12 (45.4)	32 (121)	12 (45.4)	32 (121)
			150	10.3	15 (56.8)	16 (60.6)	15 (56.8)	42 (159)	15 (56.8)	42 (159)
			200	13.8	15 (56.8)	16 (60.6)	17 (64.3)	43 (163)	17 (64.3)	43 (163)
300			20.7	14 (53.0)	-	21 (79.5)	-	21 (79.5)	-	
400			27.6	12 (45.4)	-	25 (94.6)	-	25 (94.6)	-	
15 to 40 PSIG (1.0 to 2.8 BAR)	40	2.8	60	4.1	6.7 (25.4)	13 (49.2)	6.7 (25.4)	14 (53.0)	6.7 (25.4)	19 (71.9)
			75	5.2	8.3 (31.4)	18 (68.1)	8.3 (31.4)	23 (87.1)	8.3 (31.4)	25 (94.6)
			100	6.9	11 (41.6)	19 (71.9)	11 (41.6)	28 (106)	11 (41.6)	31 (117)
			150	10.3	14 (53.0)	20 (75.7)	14 (53.0)	40 (151)	14 (53.0)	40 (151)
			200	13.8	16 (60.6)	19 (71.9)	16 (60.6)	49 (185)	16 (60.6)	49 (185)
			300	20.7	18 (68.1)	19 (71.9)	21 (79.5)	45 (170)	21 (79.5)	45 (170)
35 to 80 PSIG (2.4 to 5.5 BAR)	60	4.1	75	5.2	6.4 (24.2)	19 (71.9)	6.4 (24.2)	19 (71.9)	6.4 (24.2)	19 (71.9)
			100	6.9	9.2 (34.8)	20 (75.7)	9.2 (34.8)	23 (87.1)	9.2 (34.8)	24 (90.8)
			150	10.3	13 (49.2)	24 (90.8)	13 (49.2)	36 (136)	13 (49.2)	36 (136)
			200	13.8	16 (60.6)	26 (98.4)	16 (60.6)	42 (159)	16 (60.6)	51 (193)
			300	20.7	20 (75.7)	25 (94.6)	20 (75.7)	60 (227)	20 (75.7)	60 (227)
			400	27.6	22 (83.3)	23 (87.1)	22 (83.3)	60 (227)	22 (83.3)	66 (250)
	80	5.5	100	6.9	7.7 (29.1)	19 (71.9)	7.7 (29.1)	21 (79.5)	7.7 (29.1)	22 (83.3)
			150	10.3	12 (45.4)	20 (75.7)	12 (45.4)	35 (132)	12 (45.4)	41 (155)
			200	13.8	15 (56.8)	24 (90.8)	15 (56.8)	43 (163)	15 (56.8)	49 (185)
			300	20.7	20 (75.7)	26 (98.4)	20 (75.7)	60 (227)	20 (75.7)	60 (227)
			400	27.6	23 (87.1)	25 (94.6)	23 (87.1)	70 (265)	23 (87.1)	70 (265)
			70 to 150 PSIG (4.8 to 10.3 BAR)	100	6.9	150	10.3	9.4 (35.6)	20 (75.7)	9.6 (36.3)
200	13.8	12 (45.4)				23 (87.1)	13 (49.2)	32 (121)	14 (53.0)	32 (121)
300	20.7	19 (71.9)				25 (94.6)	19 (71.9)	44 (167)	19 (71.9)	50 (189)
500	34.5	26 (98.4)				25 (94.6)	26 (98.4)	58 (220)	26 (98.4)	82 (310)
125	8.6	150		10.3	9.0 (34.1)	19 (71.9)	9.0 (34.1)	19 (71.9)	9.0 (34.1)	22 (83.3)
		200		13.8	13 (49.2)	24 (90.8)	13 (49.2)	29 (110)	13 (49.2)	31 (117)
		300		20.7	18 (68.1)	29 (110)	18 (68.1)	42 (159)	18 (68.1)	49 (185)
		500		34.5	25 (94.6)	33 (125)	25 (94.6)	74 (280)	25 (94.6)	74 (280)
150	10.3	200		13.8	11 (41.6)	25 (94.6)	11 (41.6)	28 (106)	11 (41.6)	31 (117)
		300		20.7	17 (64.3)	34 (129)	17 (64.3)	43 (163)	17 (64.3)	43 (163)
		400		27.6	23 (87.1)	33 (125)	23 (87.1)	58 (220)	23 (87.1)	66 (250)
		500		34.5	25 (94.6)	37 (140)	25 (94.6)	73 (276)	25 (94.6)	73 (276)

1. Water flow capacities based on a 20% proportional band. ()

W627 Regulator C_v Coefficients¹ with or without a downstream control line

Outlet Pressure Range	Outlet Pressure Setting		Inlet Pressure		3/4" (DN 20) Body Size		1" (DN 25) Body Size		2" (DN 50) Body Size	
	PSIG	BAR	PSIG	BAR	1/4 Inch (6.35 mm) Orifice	1/2 Inch (12.7 mm) Orifice	1/4 Inch (6.35 mm) Orifice	1/2 Inch (12.7 mm) Orifice	1/4 Inch (6.35 mm) Orifice	1/2 Inch (12.7 mm) Orifice
10 to 20 PSIG (0.7 to 1.4 BAR)	10	0.69	15	1.0	1.09	2.60	1.10	2.65	1.15	2.65
			20	1.4	1.14	2.51	1.15	2.64	1.19	2.64
			30	2.1	1.14	2.76	1.27	2.87	1.27	2.87
			60	4.1	1.14	1.64	1.27	3.22	1.27	3.28
			75	5.2	1.14	1.40	1.27	2.81	1.27	3.22
			100	6.9	1.06	1.12	1.27	2.41	1.27	3.20
			150	10.3	0.88	0.80	1.27	1.88	1.27	3.16
			200	13.8	0.68	0.70	1.27	1.49	1.27	3.15
	300	20.7	0.52	-	1.27	-	1.27	-		
	400	27.6	0.50	-	1.27	-	1.27	-		
	20	1.4	30	2.1	1.27	2.96	1.27	3.03	1.27	3.03
			50	3.4	1.27	2.33	1.27	3.48	1.27	3.48
			60	4.1	1.27	2.06	1.27	3.50	1.27	3.50
			100	6.9	1.27	1.81	1.27	3.54	1.27	3.54
			150	10.3	1.27	1.28	1.27	3.59	1.27	3.59
			200	13.8	1.13	1.02	1.27	3.14	1.27	3.16
300			20.7	0.84	-	1.27	-	1.27	-	
400			27.6	0.59	-	1.27	-	1.27	-	
15 to 40 PSIG (1.0 to 2.8 BAR)	40	2.8	60	4.1	1.27	2.49	1.27	2.56	1.27	3.48
			75	5.2	1.27	2.76	1.27	3.48	1.27	3.89
			100	6.9	1.27	2.30	1.27	3.44	1.27	3.77
			150	10.3	1.27	1.82	1.27	3.66	1.27	3.66
			200	13.8	1.27	1.40	1.27	3.75	1.27	3.75
			300	20.7	1.19	1.18	1.27	3.68	1.27	3.68
			400	27.6	0.94	-	1.27	-	1.27	-
35 to 80 PSIG (2.4 to 5.5 BAR)	60	4.1	75	5.2	1.22	3.61	1.25	3.61	1.25	3.61
			100	6.9	1.27	2.80	1.27	3.23	1.27	3.27
			150	10.3	1.27	2.37	1.27	3.56	1.27	3.59
			200	13.8	1.27	2.11	1.27	3.44	1.27	3.68
			300	20.7	1.27	1.55	1.27	3.60	1.27	3.60
	80	5.5	400	27.6	1.10	1.10	1.27	3.16	1.27	3.55
			100	6.9	1.27	3.17	1.27	3.48	1.27	3.72
			150	10.3	1.27	2.78	1.27	3.78	1.27	3.97
			200	13.8	1.27	2.31	1.27	3.66	1.27	3.78
			300	20.7	1.27	1.74	1.27	3.64	1.27	3.64
70 to 150 PSIG (4.8 to 10.3 BAR)	100	6.9	400	27.6	1.27	1.15	1.27	3.56	1.27	3.56
			150	10.3	1.12	2.32	1.15	2.85	1.15	2.85
			200	13.8	1.14	2.10	1.18	2.90	1.18	2.90
			300	20.7	1.27	1.67	1.27	2.97	1.27	3.07
	125	8.6	500	34.5	1.27	1.23	1.27	2.82	1.27	3.58
			150	10.3	1.27	2.69	1.27	2.75	1.27	3.08
			200	13.8	1.27	2.45	1.27	2.91	1.27	3.05
			300	20.7	1.27	2.04	1.27	2.98	1.27	3.14
	150	10.3	500	34.5	1.27	1.64	1.27	3.68	1.27	3.68
			200	13.8	1.27	2.80	1.27	3.18	1.27	3.47
300			20.7	1.27	2.54	1.27	3.22	1.27	3.22	
500			34.5	1.27	1.90	1.27	2.76	1.27	2.76	

1. C_v Coefficients based on a 20% proportional band.

W627 Flow Coefficients

Body Sizes Inches (DN)	Orifice size, Inches (mm)									
	Wide-Open C _v For Relief Sizing		K _M		IEC Sizing Coefficients					
	1/4 (6.4)	1/2 (12.7)	1/4 (6.4)	1/2 (12.7)	X _T		F _D		F _L	
	1/4 (6.4)	1/2 (12.7)	1/4 (6.4)	1/2 (12.7)	1/4 (6.4)	1/2 (12.7)	1/4 (6.4)	1/2 (12.7)	1/4 (6.4)	1/2 (12.7)
3/4 (20)	1.63	4.87	0.76	0.74	0.592	0.962	0.50	0.50	0.87	0.86
1 (25)	1.70	5.29			0.543	0.815				
2 (50)	1.66	5.01			0.620	1.01				

W627 Regulator Water Capacities¹ in GPM (l/min) with or without a downstream control line

Outlet Pressure Range	Outlet Pressure Setting		Inlet Pressure		3/4" (DN 20) Body Size		1" (DN 25) Body Size		2" (DN 50) Body Size	
	PSIG	BAR	PSIG	BAR	1/4 Inch (6.35 mm) Orifice	1/2 Inch (12.7 mm) Orifice	1/4 Inch (6.35 mm) Orifice	1/2 Inch (12.7 mm) Orifice	1/4 Inch (6.35 mm) Orifice	1/2 Inch (12.7 mm) Orifice
140 to 250 PSIG (9.65 to 17.2 BAR)	150	10.3	200	13.8	10 (37.9)	25 (94.6)	11 (41.6)	25 (94.6)	12 (45.4)	25 (94.6)
			250	17.2	14 (53.0)	31 (117)	14 (53.0)	31 (117)	14 (53.0)	31 (117)
			300	20.7	17 (64.3)	33 (125)	17 (64.3)	33 (125)	17 (64.3)	33 (125)
			400	27.6	20 (75.7)	34 (129)	21 (79.5)	34 (129)	21 (79.5)	34 (129)
			500	34.5	23 (87.1)	-	24 (90.8)	-	24 (90.8)	-
	200	13.8	250	17.2	12 (45.4)	30 (114)	12 (45.4)	30 (114)	13 (49.2)	30 (114)
			300	20.7	15 (56.8)	36 (136)	16 (60.6)	36 (136)	16 (60.6)	36 (136)
			400	27.6	19 (71.9)	44 (167)	20 (75.7)	44 (167)	20 (75.7)	44 (167)
			500	34.5	22 (83.3)	-	22 (83.3)	-	23 (87.1)	-
			600	41.4	25 (94.6)	-	27 (102)	-	27 (102)	-
	250	17.2	300	20.7	13 (49.2)	35 (132)	13 (49.2)	51 (193)	13 (49.2)	51 (193)
			400	27.6	18 (68.1)	46 (174)	18 (68.1)	52 (197)	18 (68.1)	52 (197)
			500	34.5	22 (83.3)	51 (193)	23 (87.1)	58 (220)	22 (83.3)	58 (220)
			650	44.8	27 (102)	-	27 (102)	-	27 (102)	-
	240 to 500 PSIG (16.5 to 34.5 BAR)	250	17.2	300	20.7	10 (37.9)	25 (94.6)	10 (37.9)	25 (94.6)	10 (37.9)
400				27.6	15 (56.8)	30 (114)	16 (60.6)	32 (121)	16 (60.6)	32 (121)
500				34.5	18 (68.1)	36 (136)	18 (68.1)	38 (144)	18 (68.1)	38 (144)
650				44.8	20 (75.7)	-	20 (75.7)	-	20 (75.7)	-
300		20.7	350	24.1	12 (45.4)	28 (106)	12 (45.4)	28 (106)	12 (45.4)	28 (106)
			400	27.6	15 (56.8)	31 (117)	16 (60.6)	32 (121)	16 (60.6)	32 (121)
			500	34.5	20 (75.7)	38 (144)	20 (75.7)	39 (148)	20 (75.7)	39 (148)
			700	48.3	27 (102)	-	27 (102)	-	27 (102)	-
400		27.6	450	31.0	14 (53.0)	36 (136)	15 (56.8)	33 (125)	15 (56.8)	33 (125)
			500	34.5	18 (68.1)	41 (155)	19 (71.9)	42 (159)	19 (71.9)	42 (159)
			750	51.7	27 (102)	-	27 (102)	-	27 (102)	-
			800	55.2	28 (105)	-	28 (106)	-	28 (106)	-
500		34.5	550	37.9	17 (64.3)	44 (267)	17 (64.3)	45 (170)	17 (64.3)	45 (170)
			600	41.4	19 (71.9)	50 (189)	20 (75.7)	51 (193)	20 (75.7)	51 (193)
			750	51.7	25 (94.6)	62 (235)	28 (106)	66 (250)	28 (106)	66 (250)
			900	62.1	27 (102)	-	28 (106)	-	28 (106)	-

1. Water flow capacities based on a 20% proportional band.

W627 Regulator C_v Coefficients¹ with or without a downstream control line

Outlet Pressure Range	Outlet Pressure Setting		Inlet Pressure		3/4" (DN 20) Body Size		1" (DN 25) Body Size		2" (DN 50) Body Size	
	PSIG	BAR	PSIG	BAR	1/4 Inch (6.35 mm) Orifice	1/2 Inch (12.7 mm) Orifice	1/4 Inch (6.35 mm) Orifice	1/2 Inch (12.7 mm) Orifice	1/4 Inch (6.35 mm) Orifice	1/2 Inch (12.7 mm) Orifice
140 to 250 PSIG (9.65 to 17.2 BAR)	150	10.3	200	13.8	1.17	2.83	1.20	2.83	1.26	2.83
			250	17.2	1.20	2.71	1.24	2.71	1.24	2.71
			300	20.7	1.25	2.51	1.30	2.51	1.30	2.51
			400	27.6	1.20	2.01	1.27	2.01	1.27	2.01
			500	34.5	1.17	-	1.23	-	1.23	-
	200	13.8	250	17.2	1.26	3.14	1.30	3.14	1.34	3.14
			300	20.7	1.30	3.05	1.34	3.05	1.34	3.05
			400	27.6	1.25	2.80	1.27	2.80	1.27	2.80
			500	34.5	1.22	-	1.27	-	1.27	-
			600	41.4	1.22	-	1.27	-	1.27	-
	250	17.2	300	20.7	1.27	3.46	1.27	5.10	1.32	5.10
			400	27.6	1.27	3.25	1.27	3.68	1.28	3.68
			500	34.5	1.27	2.92	1.27	3.33	1.28	3.33
			650	44.8	1.27	-	1.27	-	1.28	-
	240 to 500 PSIG (16.5 to 34.5 BAR)	250	17.2	300	20.7	1.00	2.46	1.03	2.52	1.03
400				27.6	1.07	2.15	1.10	2.23	1.10	2.23
500				34.5	1.02	2.08	1.02	2.17	1.02	2.17
650				44.8	1.02	-	1.02	-	1.02	-
300		20.7	350	24.1	1.17	2.63	1.18	2.69	1.18	2.69
			400	27.6	1.22	2.45	1.25	2.52	1.25	2.52
			500	34.5	1.27	2.33	1.27	2.45	1.27	2.45
			700	48.3	1.27	-	1.27	-	1.27	-
400		27.6	450	31.0	1.27	3.16	1.29	3.23	1.29	3.23
			500	34.5	1.38	3.02	1.40	3.10	1.40	3.10
			750	51.7	1.28	-	1.28	-	1.28	-
			800	55.2	1.28	-	1.28	-	1.28	-
500		34.5	550	37.9	1.40	3.57	1.42	3.64	1.42	3.64
			600	41.4	1.36	3.51	1.38	3.60	1.38	3.60
			750	51.7	1.34	3.50	1.38	3.50	1.38	3.50
			900	62.1	1.34	-	1.38	-	1.38	-

1. C_v Coefficients based on a 20% proportional band.

W627 Parts

Item	Description	Qty.	Part Number
1	Cover Adj. Screw, Plastic	1	610-053-000
2	Adjustment Screw	1	648-465-000
3	Locknut	1	634-154-000
4	Bonnet, W627 - Iron	1	604-265-000
	Bonnet, W627 - Steel		604-211-000
	Bonnet, W627 - Stainless		604-266-000
5	Vent Screw Assembly	1	836-005-000
6	Spring Guide, Upper	1	626-079-000
7	Range Spring	1	
	10-20 PSIG–Yellow		655-661-000
	15-40 PSIG–Green		655-661-001
	35-80 PSIG & 10-95–PSIG Blue		655-661-002
	70-150 PSIG–Red		655-661-003
	140-250 PSIG–Blue		655-661-002
	240-500 PSIG–Red		655-661-003
8	Spring Guide, Lower	1	643-211-000
9	Iron Spring Case Screws - W627	8	648-466-000
	Steel Spring Case Screws		648-467-003
	Steel Spring Case Screws - W627H		648-467-002
	SS Spring Case Screws		648-550-000
	SS Spring Case Screws - W627H		648-550-001
10	Diaphragm Piston	1	637-336-000
	Diaphragm Piston - W627H		637-307-000
11	Diaphragm Iron (Nitrile)	1	618-069-000
	Diaphragm Iron (Fluoro)		618-069-001
	Diaphragm Steel / SS (Nitrile)		618-070-000
	Diaphragm Steel / SS (Fluoro)		618-096-000
	Diaphragm W627H Steel / SS (Nitrile)		618-070-000
Diaphragm W627H Steel / SS (Fluoro)	618-096-000		
12	Screw, Diaphragm	1	648-463-009
	Screw, Diaphragm W627H	1	648-467-000
13	Post, Pusher Assy	1	827-005-000
	Post, Pusher PW627H Assy		827-005-001
	Post, Pusher Stainless		827-008-000
	Post, Pusher W627H Stainless		827-008-001
14	Diaphragm Case - Iron	1	629-240-000
	Diaphragm Case - Steel		629-203-000
	Diaphragm Case - Stainless		629-242-000
	Diaphragm Case - W627M Iron		629-241-000
	Diaphragm Case - W627M Steel		629-204-000
	Diaphragm Case - W627M Stainless		629-243-000
15	Lever	1	703-011-000
16	Lever Screw	2	648-474-000
17	Pin, Lever	1	635-057-000
18	Lever Retainer	1	643-210-000
19	Stem O-ring, Nitrile	1	649-000-003
	Stem O-ring, Fluorocarbon		649-000-343
20	Stem Backup Ring, TFE	2	644-047-000
21	Pin, Groove	1	635-076-000
22	Stem Guide	2	626-115-000
	Stem Guide W627M		626-081-000
23	Pin Clip	1	635-056-000
24	Stem, 316SS	1	689-005-000

Item	Description	Qty.	Part Number
28	Seat assembly - 316SS Holder / Nitrile	1	822-020-000
	Seat assembly - 316SS / Nylon		822-020-001
	Seat assembly - 316SS / Fluorocarbon		822-040-001
29	Orifice - SS - 1/4"	1	688-014-002
	Orifice - SS - 1/2"		688-014-000
30	Iron Body - 3/4 NPT	1	664-280-000
	Iron Body - 1 NPT		664-280-001
	Iron Body - 2 NPT		664-282-000
	Steel Body - 3/4 NPT		664-281-000
	Steel Body - 1 NPT		664-281-001
	Steel Body - 2 NPT		664-283-000
	LCC Body - 3/4 NPT		664-325-000
	LCC Body - 1 NPT		664-325-001
	LCC Body - 2 NPT		664-326-000
	Stainless Body - 3/4 NPT		664-394-000
	Stainless Body - 1 NPT		664-394-001
	Stainless Body - 2 NPT		664-395-000
	Steel Body - 3/4 NPT Socket Weld		664-356-000
	Steel Body - 1 NPT Socket Weld		664-358-000
	Steel Body - 2 NPT Socket Weld		664-359-000
	Stainless Body - 3/4" Socket Weld		664-422-000
	Stainless Body - 1" Socket Weld		664-423-000
Stainless Body - 2" Socket Weld	664-424-000		
32	Diaphragm Spacer W627H	1	654-167-000
33	O-ring, Spacer W627H - Nitrile	1	649-279-000
	O-ring, Spacer W627H - Fluorocarbon		649-279-001
34	O-ring, Stem Guide - Nitrile	2	649-281-000
	O-ring, Stem Guide - Fluorocarbon		649-281-001
36	Backup Ring, Stem Guide	2	644-048-000
37	Body Screws / Iron & Steel Housing (Not Shown)	2	648-467-001
	Body Screws / SS Housing (Not Shown)		648-549-000
38	Spring Guide, Lower (W627H & W627HM only)	1	637-307-000
40	Name Plate Drive Screw (not shown)	2	648-464-000

W627 Parts

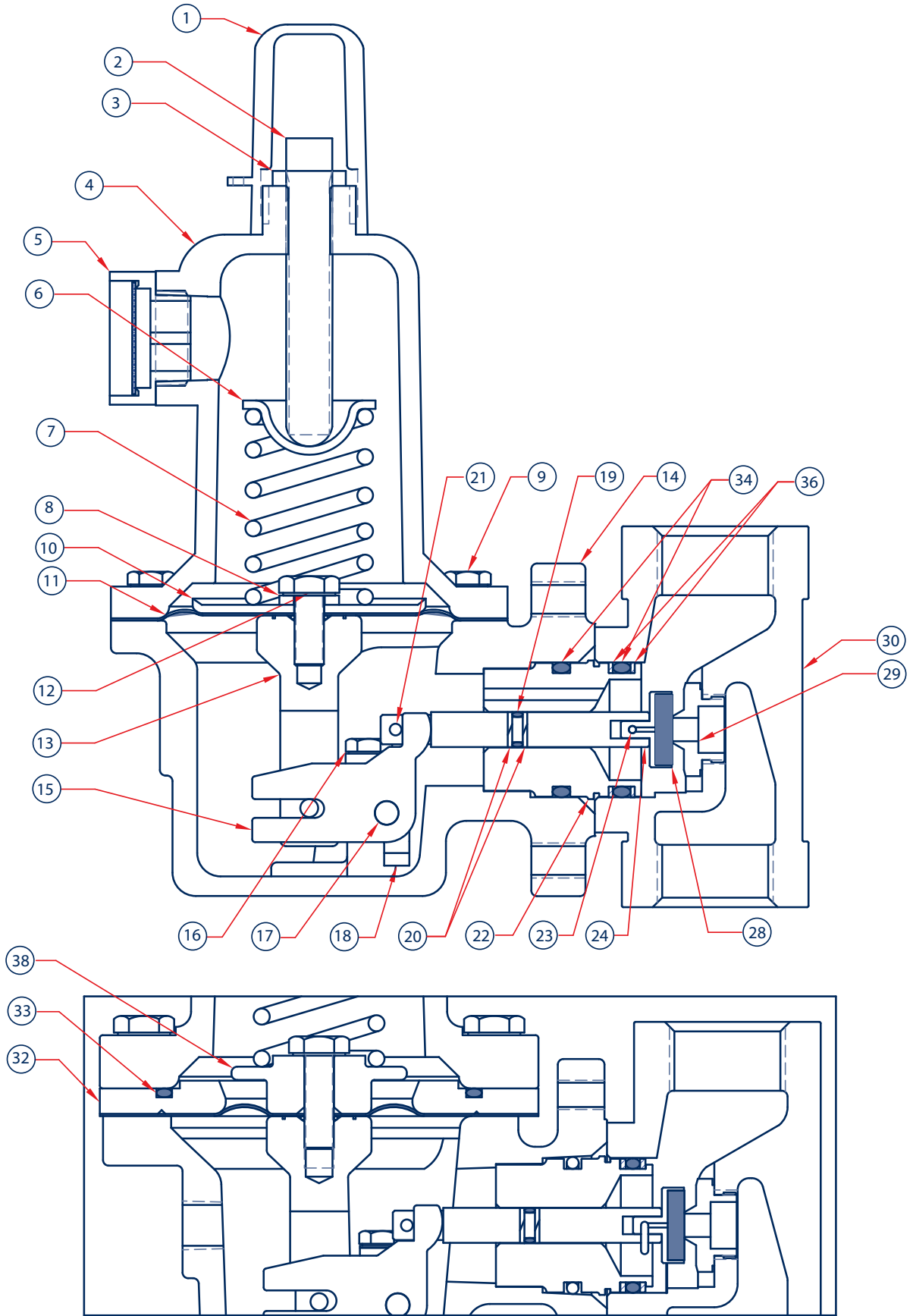

W627 Dimensions

Steel/Steel Units

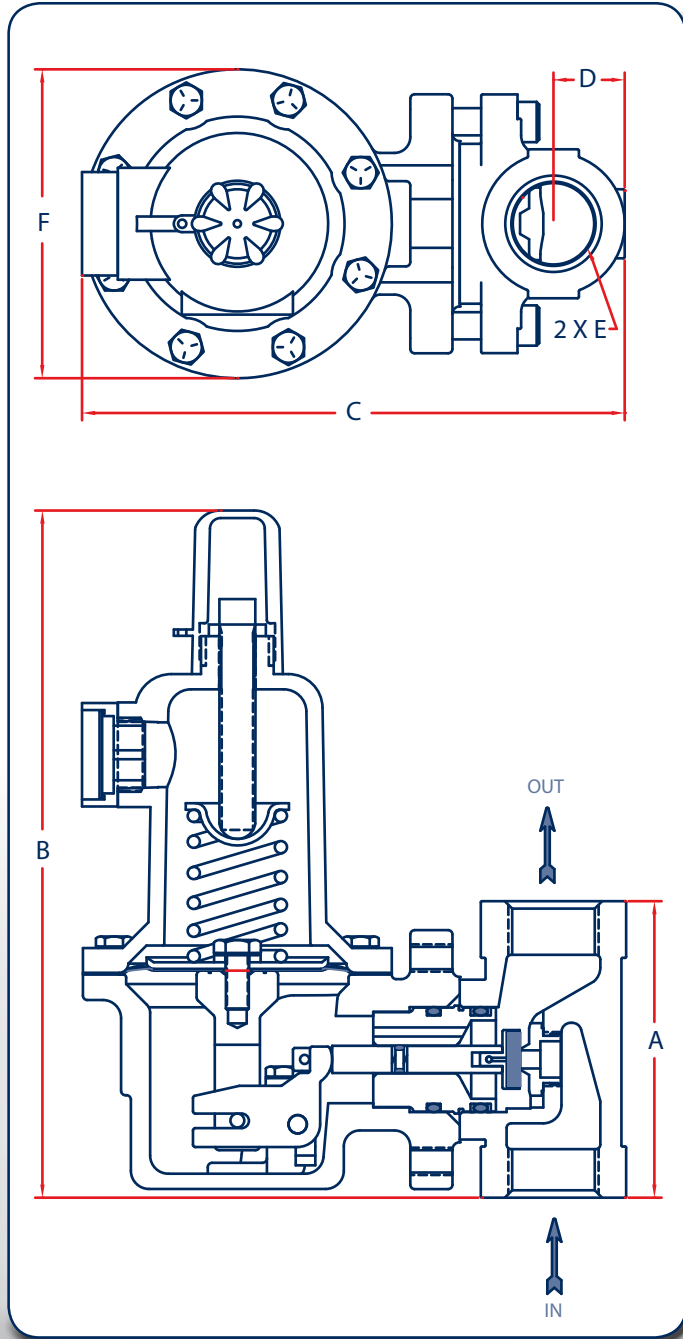

Type	Body Size		A	B	C	D	E	F*
627 & 627M	3/4"	mm	104	243	190	26	3/4"	108
		inches	4.08	9.54	7.46	1.0		4.25
	1"	mm	104	243	190	26	1"	108
		inches	4.08	9.54	7.46	1.0		4.25
	2"	mm	127	256	218	43	2"	108
		inches	5.0	10.06	8.56	1.69		4.25
627H & 627HM	3/4"	mm	104	250	194	26	3/4"	120
		inches	4.08	9.82	7.62	1.0		4.70
	1"	mm	104	250	194	26	1"	120
		inches	4.08	9.82	7.62	1.0		4.70
	2"	mm	127	265	224	43	2"	120
		inches	5.0	10.44	8.80	1.69		4.70

*F Dimensions for steel W627 and W627M - 120 mm/4.7 inches

W627H

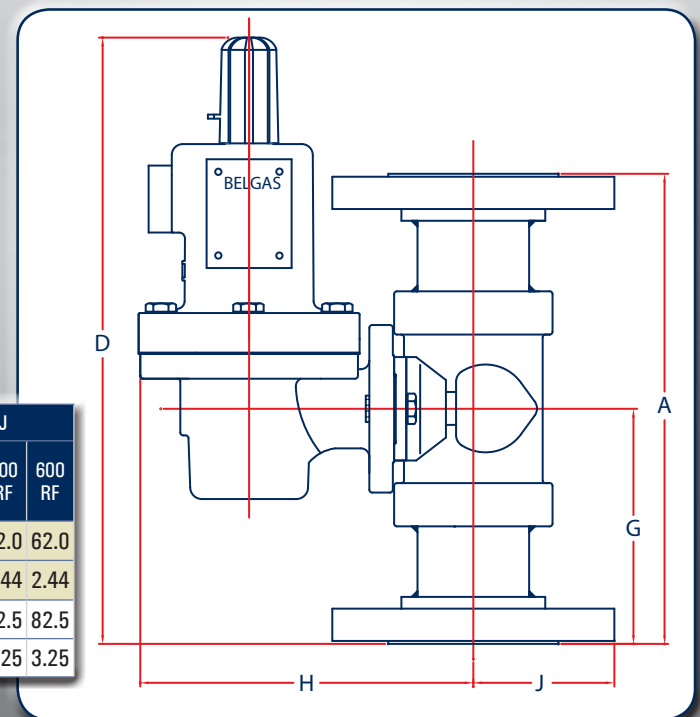
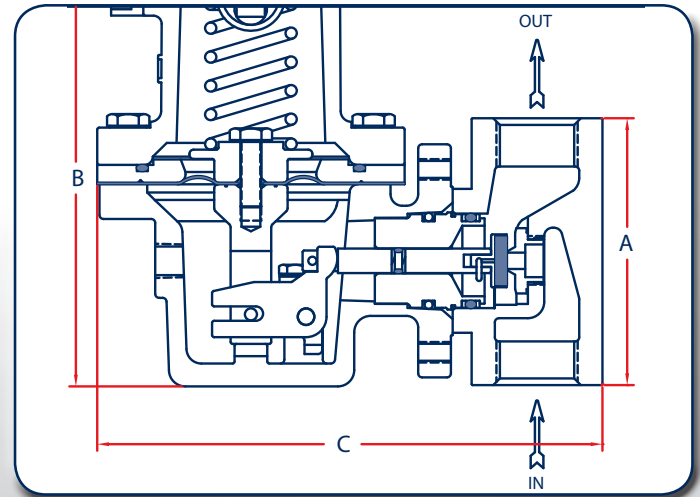

W627 Dimensions

Flange Units

Type	Body Size	A			D			G			Steel	J			
		150 RF	300 RF	600 RF	150 RF	300 RF	600 RF	150 RF	300 RF	600 RF		150 RF	300 RF	600 RF	
W627 Flanged Units	1"	mm	184	197	210	286	292	298	91.9	98.6	105	172	53.8	62.0	62.0
		in.	7.25	7.75	8.25	11.24	11.5	11.75	3.62	3.88	4.12	6.75	2.12	2.44	2.44
	2"	mm	254	267	286	321	327	337	127	133	143	181	76.2	82.5	82.5
		in.	10	10.5	11.25	12.63	12.88	13.25	5	5.25	5.62	7.12	3	3.25	3.25