

BARTON®

# Chart Recorders

## *Models 202E, 202ER, 202N, 242E, and J8A*

Barton® chart recorders are the industry standard for accurate, reliable measurement and recording of pressure, differential pressure, and temperature in a wide variety of applications. In addition, DP models utilize Barton's® rupture-proof bellows DPU as the actuating unit – with features like overrange protection and pulsation dampening (on some models).

### Common Components

- Case: Is made of rugged, lightweight die-cast aluminum that features a built-in rain-shield. It is finished in polyurethane electrostatic powder paint that has a high resistance to weathering, scratches, and industrial fumes. aircraft-type door hinge (made of 302 SST) provides excellent resistance to salt spray and H<sub>2</sub>S. A closed neoprene gasket, non-absorbent to fluids and resistant to oils and most solvents, provides the seal between the door and the case.
  - Optional "S" versions use a stainless steel case or a corrosion resistant "offshore coating" for harsh saltwater environments.
- Chart Drive: Available in battery and spring-wound versions with a wide variety of chart speeds. All chart drives, with simple positive chart lock hub, are interchangeable.
- NuFlo™ Charts: Are made from "woodfree" paper – a special low shrinkage high quality product that eliminate eccentric and elliptical errors. Charts are shrink wrapped to help maintain the factory default size until it is opened by the user. Once a box of charts is opened, it can be stored in the supplied plastic re-sealable storage bag.
- Recording Mechanism: All parts are stainless steel for long life. The pen mount is exceptionally rugged and pen shafts are fitted with ball pivots to minimize friction. All links are adjustable, with micrometer adjustments for accurate calibration. All adjustments have screwdriver slots to simplify calibration. Disposable pens are standard.
- Pressure Elements: Used in Models 202E, 242E, and J8A are precision wound helical-type available in a variety of materials – pressure ranges from 0-30-in. mercury vacuum (0 - 14.7 psi/1 bar) to 0 - 30,000 psi (0 - 2,068 bar). The Model 202N uses a K-Monel element – pressure ranges from 0 - 250 psi (0 - 17 bar) to 0 - 6,000 psi (0 - 414 bar).



Connections available in 1/4-in. NPT for ranges less than 10,000 psi (689 bar). Ranges greater than 10,000 PSI (689 bar) utilize an Aminco 9/16–18 (1/4-in. O.D.) female connection.

- Thermal Systems: Consist of a bourdon tube, a capillary (w/SST armor), and a bulb (w/bendable extension). All parts are SST. Systems available in Class V (mercury fill w/11/16-in. O.D. bulb) or Class I (hydrocarbon fill w/3/8-in. O.D. bulb). Invar available in Class V only. Standard temperature ranges are: 0°F to +[100, 150, 200, or 300]°F (-18°C to +[38, 66, 93, or 149]°C). Thermal system must have a span of more than 70°F (50°C). The high temperature limit must be greater than 95°F and (35°C)
  - Class VA (self/full compensation): -40°F/°C to +1200°F (+649°C)[self] or +600°F (+316°C)[fully]
  - Class VB (Case compensated): -40°F/°C to +600°F (+316°C)
  - Class IA (full) & IB (self): -200 to +500°F (-129 to +260°C)
  - Accuracy: +/- 1.0% of F.S.
  - Hardware: Capillary standard length is 10 ft. with additional lengths available.

### Models 202E/202ER (DP)

The 202E is a 12-in. chart recorder that has been widely used in gas transmission and distribution fields – accurate calibration, even under extreme variations in static pressure and ambient temperatures.

The 202E is available in 1 to 4 pen configurations (DP+3 additional pens). The additional pens can be used to record temperature and supplemental pressure data.

The unit is actuated by a Barton® Model 199 DPU, with standard and NACE units available (up to 6,000 PSI/414 bar SWP) – see DPU bulletin #21700 for details. Static pressure and temperature pens are actuated by precision wound elements (see page 1).

Model 263 option uses Foxboro-type charts.

#### Specifications

- Safe Working Pressure: up to 6,000 PSI (414 bar)
- DP Ranges: 0-10-in. w.c. to 0-100 PSID (0-25 mbar to 0-6.9 bar)
- Accuracy: +/- 0.5% F.S.
- Temperature Limits: -40°F/°C to +180°F (+82°C)

Model 202ER – a reverse-acting version that sets zero on outer perimeter of the chart for more accurate integration.

### Model 202N (DP) (NACE)

The 202N is a 12-in. chart recorder designed to measure flow, static pressure, and temperature in sour gas applications. The 202N meets all NACE requirements for H<sub>2</sub>S environments, per MR-01-75 (1991 Revision) – SWP up to 2,000 PSI (138 bar).

For ranges between 2,000 PSI (138 bar) and 6,000 PSI (414 bar), see optional NACE version of M202E.

The 202N is actuated by Barton's® M199 NACE DPU – see DPU PB for details. Static pressure measurements are provided by precision wound K-Monel helical-type elements.

All other features and benefits are the same as the 202E.

#### Specifications

- Safe Working Pressure: up to 2,000 PSI (138 bar)
- DP Ranges: 0-10-in. w.c. to 0-100 PSID (0-25 mbar to 0-6.9 bar)
- Accuracy: +/- 0.5% F.S.
- Temperature Limits: -40°F/°C to +180°F (+82°C)

### Model 242E (Temperature/Pressure)

The 242E is a 12-in. chart Temperature and Pressure Recorder-Receiver designed for general pressure applications. When functioning as a recorder-receiver, it uses a bellows-type element for pneumatic transmitter or controller input.

An optional pen mount allows use of Foxboro-type charts.

#### Receiver Bellows

Our receiver bellows are made from either phosphor bronze or 316 stainless steel. Phosphor bronze units are assembled and oven-bronzed; SST units are welded. They can receive pneumatic output signals of 3-15 PSI (207 mbar-1 bar).

#### Specifications

- Safe Working Pressure: up to 30,000 PSI (2,068 bar)
- DP Ranges: 0-10-in. w.c. to 0-100 PSID (0-25 mbar to 0-6.9 bar)
- Accuracy: +/- 1.0% F.S.
- Temperature Limits: -40°F/°C to +180°F (+82°C)

### Main Components

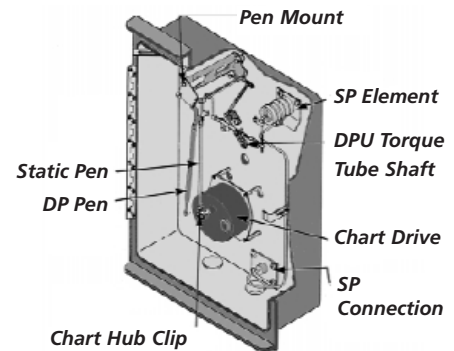

**Model J8A  
(Temperature/Pressure)**

The J8A is a compact 8-in. chart Temperature and Pressure Recorder designed for general pressure applications. Available as a single or dual pen unit, it can use any combination of pressure measuring helical elements or temperature measuring thermal systems.

- Pressure Elements: Same as those supplied for 12-in. recorders, with pressure ranges from 0-30-in. Hg to 30,000 PSI (0-14.7 PSI/1 bar to 2,068 bar).
- Case: A smaller version of the 242E, the J8A case is 3/16-in. thick, with a closed cell neoprene gasket. The standard door comes with an 8-in. square piece of glass, Plexiglas (Lexan), or 16-gauge steel plate for solid door applications.
- Overall dimensions of standard unit are: 10.5-in. wide x 13.75-in. tall x 4 5/8-in. deep.

**Mounting Options**

- Panel
- Wall
- Pipe mount, slip-on, non-thread (1-1/2-in. or 2-in. std. pipe)
- Portable Stand, w/handle
- Wall Shock-Mounting Kit

**Ordering**

When ordering recorder, please specify the following items:

- Model Number
- Housing Pressure Rating (SWP) (DPU Models)
- Housing and Bellows Materials (DPU Models)
- Process Material Contacting Bellows (DPU Models)

- Differential Pressure Range (DPU Models)
- Pressure Elements (Range, Material)
- Pens (disposable)
- Chart Drive (type and rotation)
- Thermal Systems (range, capillary length, Class)
- Mounting (pipe, wall, flush panel, portable stand) or shock mount
- Charts



**Recorder Dimensions**

Overall case dimensions for Models 202, 242, and 208:

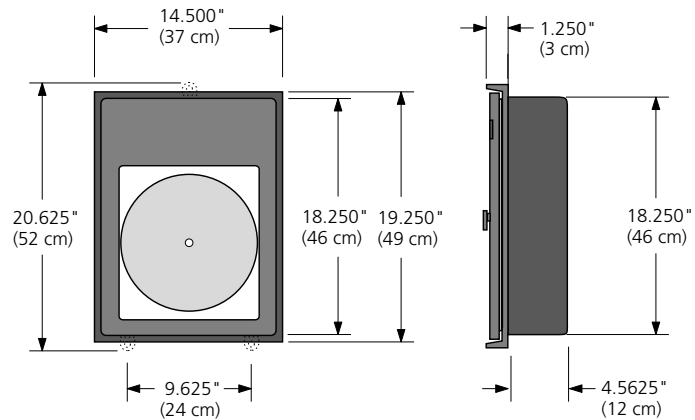

**Recorder Weights**

Ind. Model	202E/202ER/202N					
	Forged Steel			Forged SST		
	2500	4500	6000	1000	3000	6000
Safe Working	68	69	71	59	69	71
Pressure (psi)	(31)	(31)	(32)	(27)	(31)	(32)

The M242E or J8A gross weight is approx. 25 lbs (11 kg). For SST "S" versions, add 10 lbs (6 kg) to standard weights.

---

WARRANTY-LIMITATION OF LIABILITY: Seller warrants only title to the product, supplies, and materials and that, except to software, the same are free from defects in workmanship and materials for a period of one (1) year from the date of delivery. Seller does not warranty that software is free from error or that software will run in an uninterrupted fashion. Seller provides all software "as is". THERE ARE NO WARRANTIES, EXPRESSED OR IMPLIED, OF MERCHANTABILITY, FITNESS OR OTHERWISE WHICH EXTEND BEYOND THOSE STATED IN THE IMMEDIATELY PRECEDING SENTENCE. Seller's liability and Buyer's exclusive remedy in any case of action (whether in contract, tort, breach of warranty or otherwise) arising out of the sale or use of any product, software, supplies, or materials is expressly limited to the replacement of such products, software, supplies, or materials on their return to Seller or, at Seller's option, to the allowance to the customer of credit for the cost of such items. In no event shall Seller be liable for special, incidental, indirect, punitive or consequential damages. Seller does not warranty in any way products, software, supplies, and materials not manufactured by Seller, and such will be sold only with the warranties that are given by the manufacturer thereof. Seller will pass only through to its purchaser of such items the warranty granted to it by the manufacturer.

#### MEASUREMENT SYSTEMS

Formerly: NuFlo Measurement Systems • Barton Instrument Systems • Caldon, Inc.

NORTH  
AMERICA

**1.800.654.3760**

ms-us@c-a-m.com

ASIA  
PACIFIC

**65.6737.0444**

ms-asiapacific@c-a-m.com

EUROPE, MIDDLE EAST  
& AFRICA

**44.1243.826741**

ms-uk@c-a-m.com

**USA:** Houston, TX • Corpus Christi, TX • Kilgore, TX • Odessa, TX • Dallas, TX • Tulsa, OK  
Duncan, OK • Denver, CO • Bakersfield, CA • Shreveport, LA • Lafayette, LA  
Houma, LA • Pittsburgh, PA • Laurel, MS • Dunbar, WV • Casper, WY • Charleston, WV

**CANADA:** Calgary, AB • Edmonton, AB

**INTERNATIONAL:** Aberdeen, Scotland • Beijing, China • Bognor Regis, UK  
Dubai, UAE • Hassi Messaoud, Algeria • Kuala Lumpur, Malaysia • Singapore

**HOUSTON HEAD OFFICE: 281.582.9500 • [www.c-a-m.com/flo](http://www.c-a-m.com/flo)**