

F289 Pilot Operated Back Pressure Regulator



- Throttling Type Relief
- Compact
- Tight Shutoff
- High Flow Rates
- Reliability Due to Simplicity

The Type F289 is a Pilot Operated Back Pressure Regulator that functions as a high flow relief valve with an adjustable set point. The F289 can be used in place of a standard relief valve to provide protection against over pressurization in the downstream system. The pilot regulator allows for accurate back pressure control with minimal buildup over the set pressure for full opening of the main valve.

Applications

- Fuel Gas Relief
- Gas Gathering Relief

Specifications

Port Size	F289 1"		F289 2"	
	1 NPT		2 NPT	
Maximum Relief Inlet Pressure	50 PSIG above max output or 110 PSIG Max.	7.6 BAR	15 PSIG	1.0 BAR
Relief Set Pressure Ranges	10 - 18 PSIG	.7-1.2 BAR	14" - 2 PSIG	.04 - .14
	18 - 30 PSIG	1.2-2.1 BAR	2 - 10 PSIG	.14 - .7
	30 - 100 PSIG	2.1-6.9 BAR		
Temperature Range	-20-150 °F with Nitrile and Neoprene		-20-150 °F with Nitrile and Neoprene Elastomers	
	0-300 °F with Fluoroelastomer		0-300 °F with Fluoroelastomer	
Approximate Weight	2.5 lbs.	1.133 kg	15.5 lbs.	7.030 kg

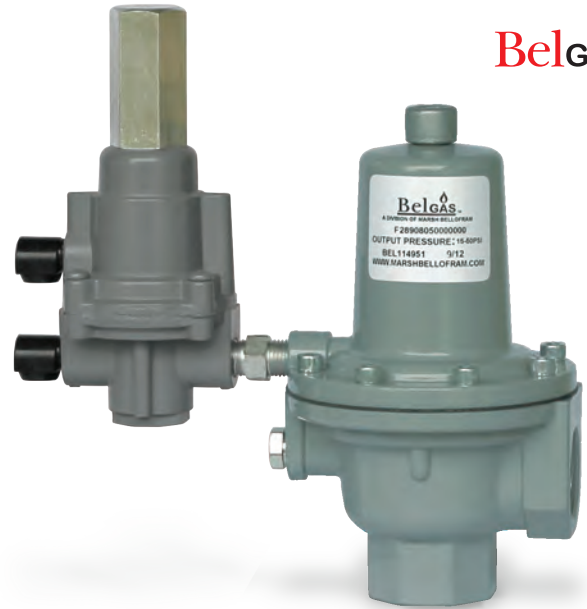

Materials of Construction

	F289 1"	F289 2"
Body, Bonnet	Aluminum	Cast Iron Body with Aluminum Bonnet
Diaphragm	Nitrile or Fluoroelastomer	Nitrile or Fluoroelastomer
Gaskets	Neoprene	Neoprene/Composite
O-rings	Nitrile or Fluoroelastomer	Nitrile or Fluoroelastomer
O-ring Piston and spacer	Aluminum	N/A
Seat Washer	N/A	Stainless Steel
Pitot Tube	Aluminum	Brass or Stainless Steel
Main Seat	N/A	Brass or Stainless Steel
Spring	Zinc-plated steel	Zinc-Plated Steel
Diaphragm Piston	Zinc-plated steel	Zinc-Plated Steel
Closing Cap	N/A	Zinc

F289 1" Part Matrix

F28908	0	0	0	0	0	0
	↑	↑	↑	↑	↑	↑
						Output Ranges
						PSIG
						BAR
						018
						10 - 18
						0.7 - 1.3
						030
						18 - 30
						1.3 - 2.1
						100
						30 - 100
						2.1 - 7.0
						O-ring / Diaphragm Material
						0
						Nitrile (NBR)
						1
						Fluoroelastomer (FKM)

F289 2" Part Matrix

F28916	0	0	0	2
	↑	↑	↑	↑
				Output Ranges
				W.C. or PSIG
				BAR
				002
				14" W.C - 2 PSIG
				0.04 - 0.14
				010
				2 - 10 PSIG
				0.14 - 0.7
				O-ring / Diaphragm Material
				0
				Nitrile (NBR)
				1
				Fluoroelastomer (FKM)
				Trim Material
				0
				Brass
				1
				Stainless Steel



F289 1 NPT Main Valve Capacities and PL82 Pilot

Main Valve Spring Part Number, and Color	Set Pressure Range		Set Pressure ¹		Build-up Over Set Pressure to Begin Opening Main Valve ²		Build-up Over Set Pressure to Fully Open Main Valve ³		Pressure Drop Below Set Pressure to Reseat Pilot		Capacities of 0.6 Specific Gravity Natural Gas ⁴	
	PSIG	BAR	PSIG	BAR	PSIG	BAR	PSIG	BAR	PSIG	BAR	SCFH	Nm ³ /h
For set pressures up to 30 psig / 2.1 bar	10 to 18	0.69 to 1.2	10	0.69	0.8	0.055	1.0	0.07	1.0	0.07	23,000	616
			15	1.0							29,000	777
			18	1.2							32,000	858
	18 to 30	1.2 to 2.1	18	1.2	0.9	0.062	1.2	0.08	1.0	0.07	32,000	858
			25	1.7							39,000	1,045
			30	2.1							44,000	1,179
For set pressures over 30 psig / 2.1 bar	30 to 100	2.1 to 7.0	30	2.1	1.4	0.10	1.9	0.13	1.0	0.07	44,000	1,179
			40	2.8							54,000	1,447
			50	3.4							64,000	1,715
			60	4.1							73,000	1,956
			70	4.8	1.6	0.11	2.1	0.14	1.0	0.07	83,000	2,224
			80	5.5							92,000	2,466
			90	6.2							102,000	2,734
			100	7.0							111,000	2,975

1. Set pressure is defined as the pressure at which the pilot exhaust starts to bubble (discharge).
2. Crack pressure is the inlet pressure at which the main valve starts audible flow.
3. Inlet pressure buildup over the set pressure to achieve wide-open capacity.
4. Capacities with inlet piping equal to body size and without outlet piping.

F289 2 NPT Main Valve Capacities and PL83 & PL82 Pilot

Relief Set Pressure Range, Spring Part Number, and Color	Set Pressure ¹		Buildup Over Set Pressure to Fully Open Main Valve ²		Pressure Drop Below Set Pressure to Reseat Pilot		Capacities of 0.6 Specific Gravity Natural Gas ³	
	PSIG	BAR	PSIG	mBAR	PSIG	mBAR	SCFH	Nm ³ /h
14-inches w.c. to 2 PSIG (35 mbar to 0.14 BAR) PL83	0.5	0.03	0.25	17	0.25	17	18,700	501
	1.0	0.07					24,000	643
	1.5	0.10					28,400	761
	2.0	0.14					32,100	860
2 to 10 PSIG (0.14 to 0.69 BAR) PL82	2.0	0.14	0.30	21	0.30	21	32,500	871
	4.0	0.28					44,300	1,187
	6.0	0.41					53,700	1,439
	8.0	0.55					62,000	1,662
	10.0	0.69					69,500	1,863

1. Set pressure is defined as the pressure at which the pilot exhaust starts to bubble (discharge).
2. Inlet pressure buildup over the set pressure to achieve wide-open capacity.
3. Capacities with inlet piping equal to body size and without outlet piping.

F289 Wide Open Flow Coefficients

1 NPT Main Valve				2 NPT Main Valve			
Inlet Piping Size	C ₀	C _v	C ₁	Inlet Piping Size	C ₀	C _v	C ₁
Line Size Equals Body Size [1-inch (25 mm) Inlet Piping]	740	23.1	32	Line Size Equals Body Size [2-inch (51 mm) Inlet Piping]	2,290	73.4	31.2
2:1 Line Size to Body Size Piping [2-inch (51 mm) Inlet Piping]	560	17.5		2:1 Line Size to Body Size Piping [4-inch (102 mm) Inlet Piping]	2,050	65.7	

1. Wide-open flow coefficients without outlet piping and outlet screen.

F289 1" Parts

Item	Description	Part Number	
1	Body, Aluminum	664-295-000	
2	Diaphragm Nitrile	804-240-002	
	Assembly Fluoroelastomer	804-240-003	
3	Pipe Plug, Plated Steel	639-099-000	
4	Machine Screw (8 required)	648-466-005	
5	Range 10 - 30 PSIG, Pink	655-688-000	
	Spring 30 - 100 PSIG, Red	655-689-000	
6	Spring Guide, Plated Steel	626-079-000	
7	Copper Gasket	624-090-000	
8	Adjustment Screw	648-554-000	
9	Bonnet, Aluminum	604-237-000	
10	Machine Screw, Stainless Steel (2 required)	648-488-000	
11	Gasket, Neoprene	624-063-000	
12	Screen, Stainless Steel	647-018-000	
13	Retaining Ring, Plated Steel	644-051-000	
14	1/4" to 1/4" Pipe Nipple	622-056-000	
15	PL82 Pilot Regulators	10-18 PSI, Nitrile	832-833-018
		10-18 PSI, Fluoroelastomer	832-833-021
		18-30 PSI, Nitrile	832-833-033
		18-30 PSI, Fluoroelastomer	832-833-035
		30-100 PSI, Nitrile	832-833-020
		30-100 PSI, Fluoroelastomer	832-833-023

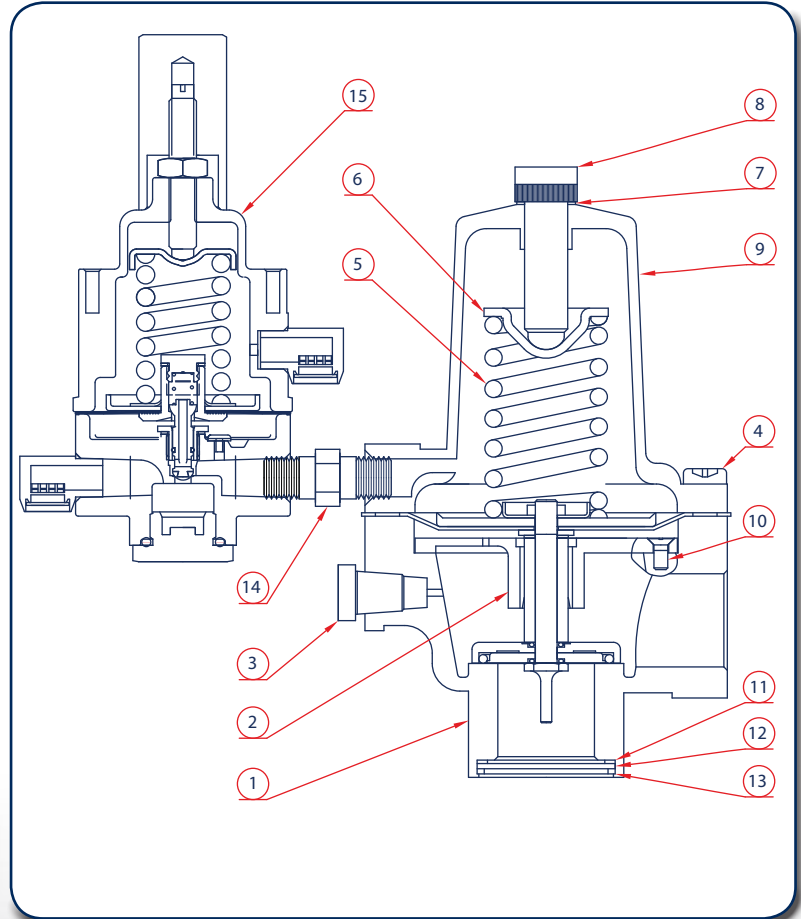

F289 1" Regulator Rebuild Kits

	Kit Includes	Part Number
F289 1"	Nitrile Diaphragms, Screen & Gasket	971F28900
F289 1"	Fluorocarbon Diaphragm, Screen & Gasket	971F28901

F289 1" Pilot Dimensions

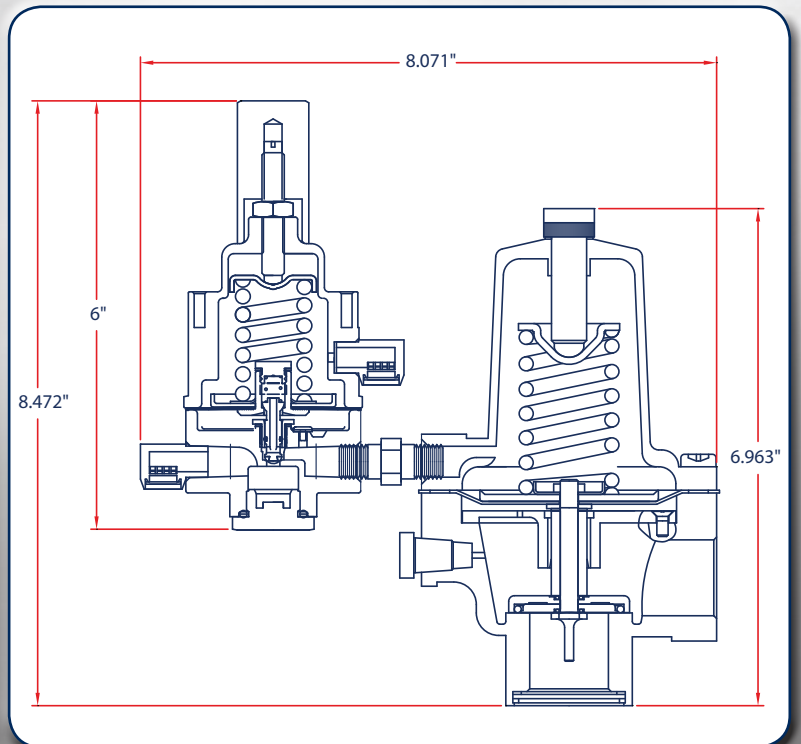

F289 2" Parts

Item	Description	Part Number	
1	Gasket, Neoprene	624-066-000	
2	Screen, Stainless Steel	647-020-000	
3	Body, Cast Iron	664-302-000	
4	Main Seat		
	Brass	650-132-000	
5	O-Ring		
	Stainless Steel	650-133-000	
6	PL82/PL83 Pilot Reg.	Nitrile	649-302-000
		Fluoroelastomer	649-301-000
		PL82 2-10 PSI, Nitrile	832-833-032
		PL82 2-10 PSI, Fluoroelastomer	832-833-034
7	1/4" to 1/4" Pipe Nipple	PL83 14"-2 PSI, Nitrile	833-032-000
		PL83 14"-2 PSI, Fluoroelastomer	833-032-001
8	Spring	14" W.C. - 2 PSIG White	655-751-000
		2 - 10 PSIG Blue	655-691-000
9	Bonnet, Aluminum	604-558-000	
10	Closing Cap Gasket, Neoprene	624-069-000	
11	Closing Cap	610-071-000	
12	Adjusting Screw, Zinc	648-499-000	
13	Upper Spring Seat Washer	662-206-000	
14	Machine Bolt (8 required)	648-466-000	
15	Machine Screw, Stainless Steel (4 required)	648-500-000	
16	Low Pipe Plug, Plated Steel	639-099-000	
17	Seat Gasket, Neoprene	624-071-000	
18	Retaining Ring	644-054-000	
19	Plugged Pitot Tube	Brass	660-088-000
		Stainless Steel	660-088-001
20	Gasket, Neoprene (3 required)	624-065-000	
21	O-Ring, Washer, Stainless Steel	Brass	654-181-000
		Stainless Steel	654-182-000
22	Spacer	637-315-000	
23	Diaphragm Head, Plated Steel	634-173-000	
24	Hex Nut, Plated Steel	662-208-000	
25	Snap Washer, Plated Steel	643-197-000	
26	Lower Spring Retainer, Zinc Plated Steel	Nitrile	618-071-000
		Fluoroelastomer	618-071-001
27	Diaphragm	622-056-000	
28	1/4" to 1/4" Pipe Nipple		

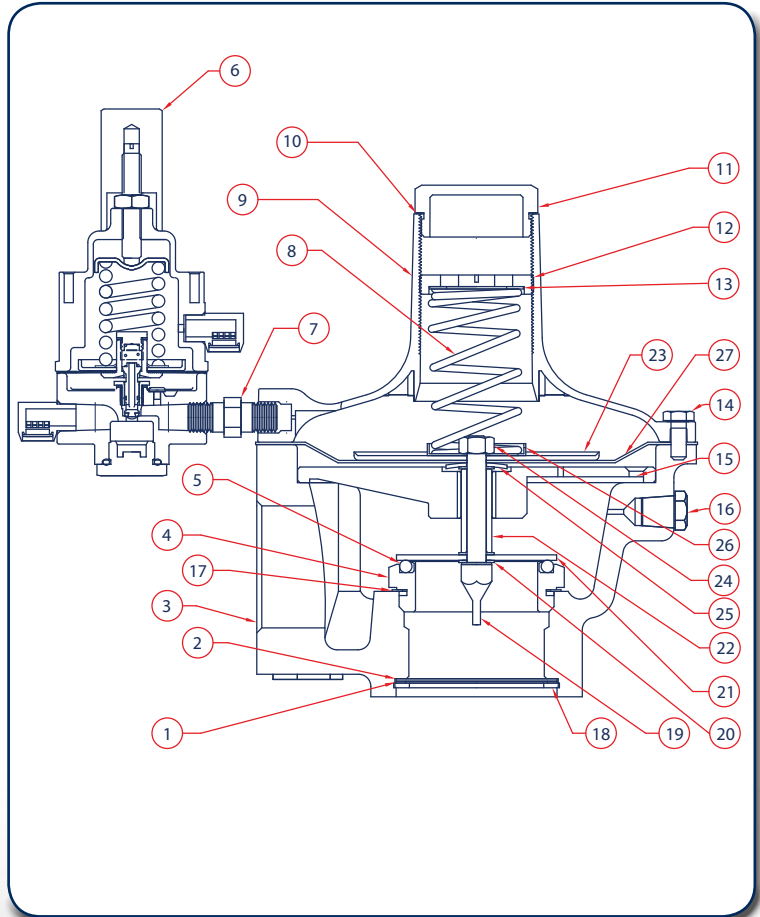

F289 2" Dimensions

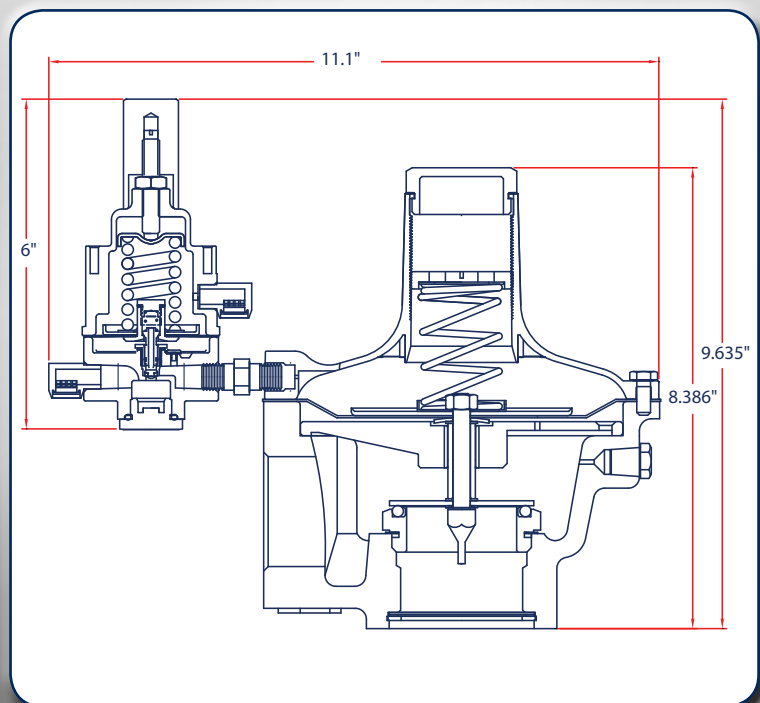

F289 2" Regulator Rebuild Kits

	Kit Includes	Part Number
F289 2"	Nitrile Diaphragms, Screen, Screen Gasket (Neoprene), Composite Gaskets (Qty.3)	971 F28 902
F289 2"	Fluorocarbon Diaphragm, Screen, Screen Gasket (Neoprene), Composite Gaskets (Qty. 3)	971 F28 903