

rotork®

Keeping the World Flowing
for Future Generations

CVA Range

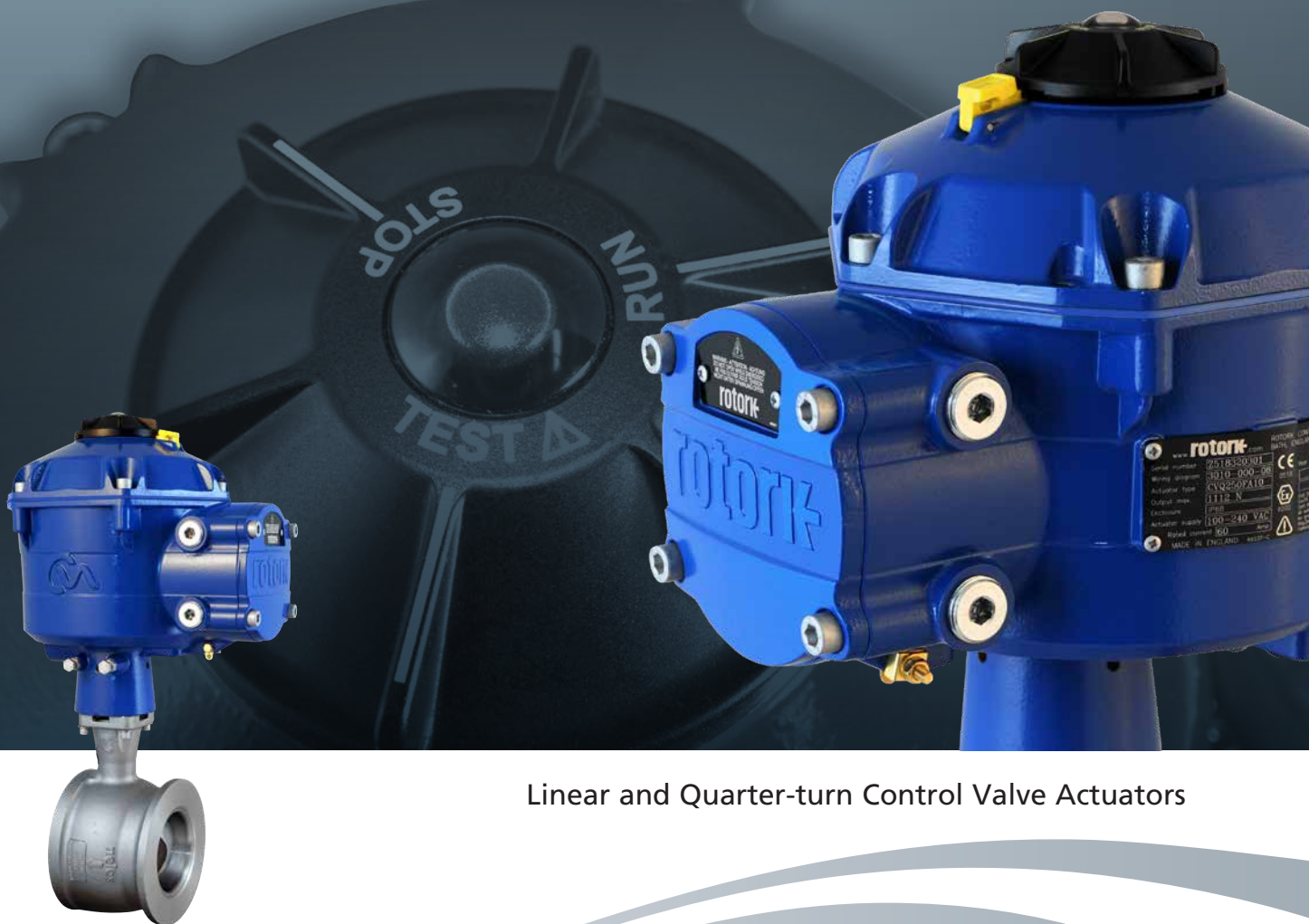

Linear and Quarter-turn Control Valve Actuators

Contents

Section	Page	Section	Page
Section 1		Section 2	
Product Overview	3	Actuator Specification (full contents list on p18)	18
CVA Actuator Range	4	Performance Summaries	19
Advanced Setup Features	5	Standard Specifications	21
Setup and Configuration	5	General Dimensions	23
Advanced Design Features	6	Design Specifications	27
Reliability	6	Non-Hazardous & Hazardous Certified Enclosures	28
Performance	6	Regulatory Standards	30
Step Response Curve	6	Paint Finish	30
Fail-to-Position	7		
Stiffness	7		
Intrinsic Safety	7		
Advanced Engineering	8		
Control & Monitoring	10		
Performance Logging	15		



Rotork is the global market leader in valve actuation products, with a fifty-year track record serving the oil and gas, power, water and waste treatment industries.

Rotork is independent of valve manufacturers allowing us to work with a wide variety of valve makers and manufacturers worldwide. We strive always for technical excellence, innovation and the highest quality standards in everything we do. As a result, our people and products remain at the forefront of actuation technology.

Uncompromising reliability is a feature of our entire product range, from our flagship electric actuator range through to our pneumatic, hydraulic and electro-hydraulic actuators, as well as gearboxes and valve accessories.

Rotork is committed to providing first class support to each client throughout the whole life of their plant, from initial site surveys to installation, maintenance, audits and repair. From our network of national and international offices, our engineers work around the clock to maintain our position of trust.

Rotork. Keeping the world flowing.

Product Overview

This brochure provides a comprehensive overview of the applications and associated functions available with Rotork CVA actuators – comprising CVL linear and CVQ quarter-turn actuators.

For information about CVA actuators and an explanation of their features see Section 1. For detailed technical specifications and performance data see Section 2.

Building on Rotork's historical success with innovative technology, the CVA offers a highly accurate and responsive method of automating control valves, without the complexity and cost of a pneumatic supply. With an increased focus on production costs and efficiency, accurate control of product through the pipeline is paramount. With resolution figures better than 0.1% and the ability to eliminate position overshoot, the Rotork CVA range helps to maximise product quality and plant capacity.

In keeping with Rotork's 'sealed-for-life' philosophy, all setup and configuration is performed using the freely downloadable Rotork Enlight software, so that no access is required to the main electronics compartment during commissioning. Additionally the terminal compartment is separately sealed, thus minimising the risk of moisture ingress during installation.



CVA Actuator Range

CVA Linear and Quarter-Turn Actuators

The Rotork CVA delivers a range of sizes suitable for almost all linear and quarter-turn control valve applications requiring highly accurate positioning. It offers end users high standards in performance, build quality and overall value.

Simplified Configuration

The Rotork CVA range provides simple, safe and rapid non-intrusive configuration using a generic field communicator. Actuator limit setting can be achieved using the quick setup wizard, which allows the actuator to 'set' its own end-of-travel limits.

Process Analysis

Comprehensive control valve performance information is delivered to the user via the built-in datalogger. Valve position, dwell times and load values etc. are stored in order for detailed process analysis to be carried out. This allows asset management and predictive maintenance software to collect valuable data in order to maintain plant availability and efficiency.

Features

- Linear drive action (CVL)
- Quarter-turn drive action (CVQ)
- Continuous unrestricted modulation duty – S9
- On-board datalogger included as standard
- Configurable fail-to-position option using supercapacitor technology
- Watertight IP68 and explosionproof enclosures
- Single-Phase or Direct Current power supplies
- Direct torque / thrust measurement for protection and monitoring
- Double-sealing to IP68 providing protection in the most demanding environments
- *Bluetooth*[®] enabled for local setup / control and diagnostics
- Accurate and repeatable positional control using 4 to 20 mA signal
- Digital communication options including HART[®], Foundation Fieldbus[®], Profibus[®], Pakscan[™], Modbus[®] and RIRO available
- Scalable control input characterisation
- Optional Intrinsically Safe (IS) control inputs and feedback outputs
- Optional manual override



CVL Linear Actuator



CVQ Quarter-turn Actuator

Advanced Setup Features

Setup and Configuration

Setup and configuration is performed non-intrusively with CVA PC Enlight software. Alternatively, a generic field communicator or typical instrument shop HART communicator (fig. 1) is used with CVA Pocket Enlight software. All software is available for free download from www.rotork.com

Each actuator in range is uniquely displayed. Once the appropriate actuator is selected the LED on the actuator will flash blue.

Quick Setup Wizard

End-of-travel limit setting can be carried out automatically using the quick setup wizard (Fig. 2). During the setup wizard process, the CVA runs to the valve limit until it meets resistance, then backs off slightly and eases into the seat where the limit is then set. This is then repeated for the opposite direction. During the quick setup procedure the applied force can be limited for the duration of the setup. Once complete the operating force can be set to meet process requirements. During the setup the actual measured load will be displayed (Fig. 3).

When auto calibration is complete the valve travel is shown on the display.

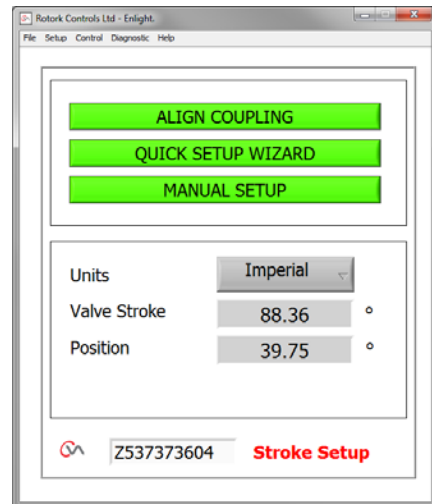

Figure 2



Figure 1. Left: ECOM, Right: Rosemount 475. The CVA can be configured using a Bluetooth wireless enabled device such as a PC or alternatively a typical shop HART communicator such as an ECOM or Rosemount 475

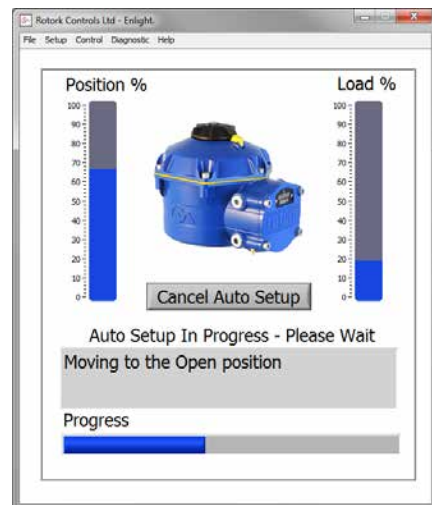

Figure 3

Advanced Design Features

Reliability

There are numerous advanced designed features that help achieve a reliable product, some of which are detailed below:

- Dual Sensor™ technology – utilising two independent position sensors, backlash and positional errors can be minimised.
- Brushless DC motor – the highly reliable brushless motor allows full continuous unrestricted modulation duty – S9.
- Simple, efficient geartrain – this simple yet durable high efficiency geartrain, which is lubricated for life, is designed for arduous control valve duties.
- Double-sealing – Rotork’s Double-Sealing to IP68 has been applied to the CVA, providing protection in the most demanding environments.

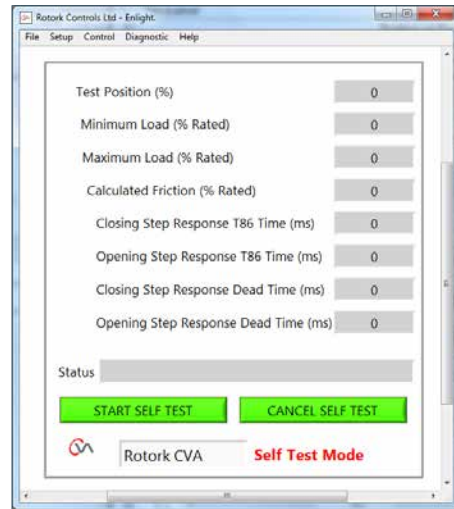

CVA Enlightenment Self Test Screen Shot.

Performance

The response below shows the low dead-time (0.075 sec) and high resolution of the CVA. With a step change of 2% the time taken for the CVA to move 1.7% is 0.175 seconds (T86b) without overshooting the set-point.

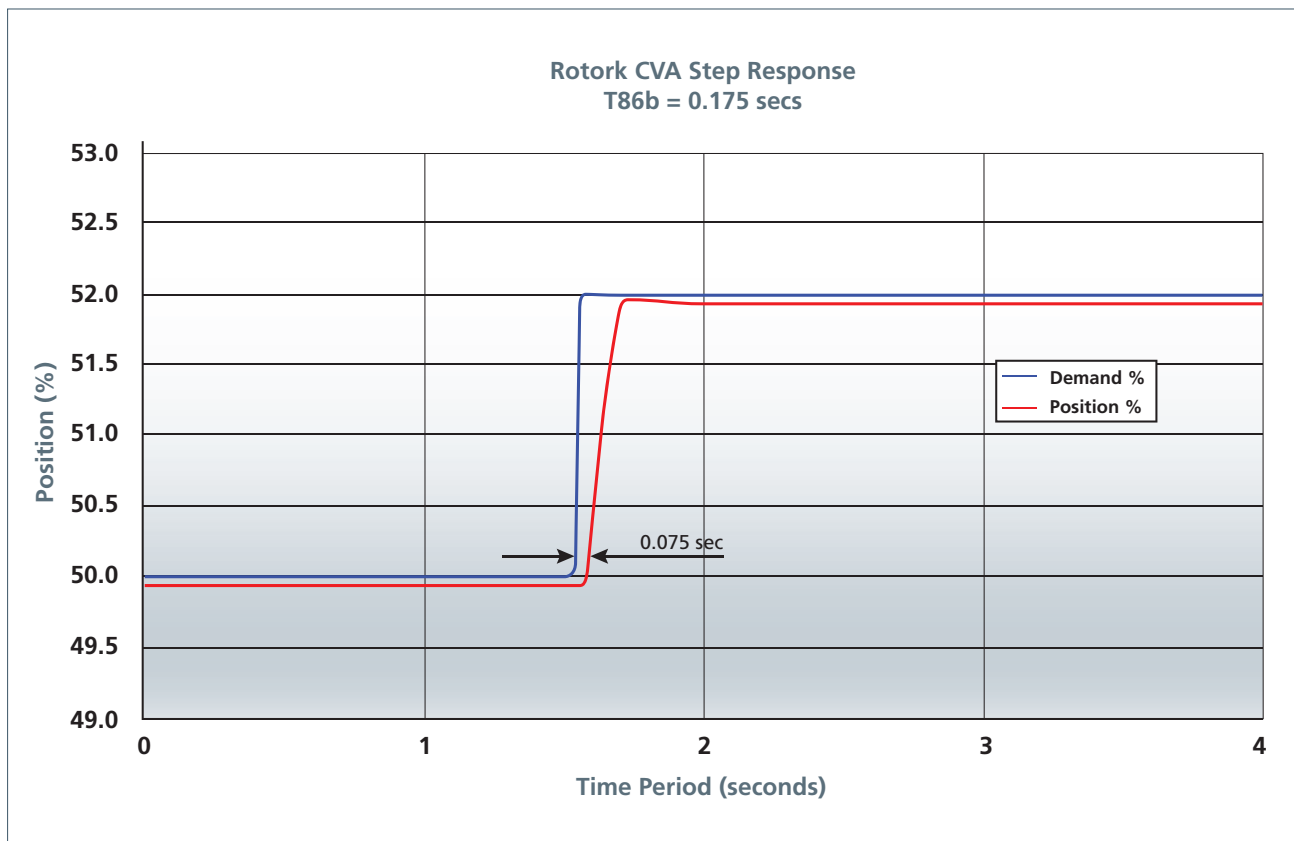

Advanced Design Features

Fail-to-Position

The CVA can be configured to perform one of the following four fail-to-position actions upon the loss of mains supply. The optional reserve power pack consists of a number of “Super Capacitors” which can store enough energy to perform the actions listed below. The capacitors are re-charged every time the mains power is reinstated and this process takes less than 1 minute to complete.

Unlike rechargeable battery technology, super capacitors do not suffer from the ‘memory’ effect of being charged/discharged many times.

- Stay Put** – Actuator remains in its current position.
- Open Limit** – Actuator moves to the position set as the open limit.
- Close Limit** – Actuator moves to the position set as the closed limit.
- Intermediate Position** – Actuator moves to a pre-programmed position.

Stiffness

The CVA is designed specifically to provide a resistant or “stiff” output drive mechanism so that process disturbance has little or no effect on valve position. Only “true” control system demand changes cause valve positioning responses.

The CVA range can withstand back-driving forces up to 125% of rated output force before any significant deflection occurs. With surges, valve position control is better maintained and therefore process quality and throughput.

An optional solenoid locking mechanism is available, which will lock the actuator in the set position when power is removed or lost. The lock can withstand back-driving forces of at least 300% of the unit rated torque/thrust.

Intrinsic Safety

The 4 to 20 mA demand and feedback signals can be supplied as an Intrinsically Safe (IS) “ia” option. This is the highest level and requires the equipment to remain Intrinsically Safe in the presence of two faults. It offers the benefit of being suitable for most explosive environments or existing IS systems.

The IS approval is only applicable for the customer I/O connections, so the actuator still has to meet the relevant approval requirements for hazardous areas. For full details of the available explosionproof approvals see section 6.2.



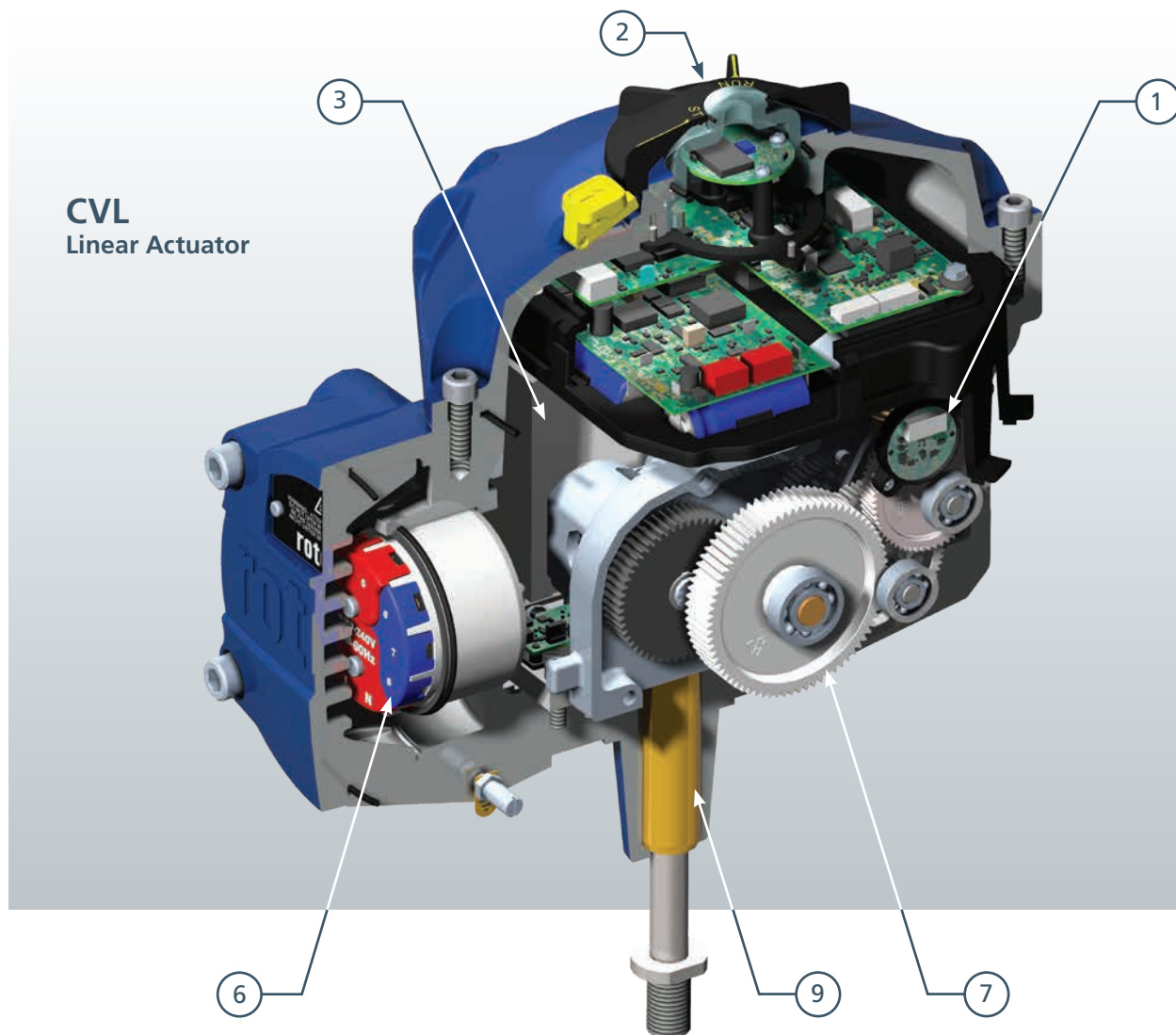

CVL
Linear Actuator

1 Dual Sensor™ Technology

In order to achieve 0.1% resolution, two independent position sensors are used to eliminate backlash and inertia effects in the gearing. The sensors are 12-bit rotary magnetic encoders, one on the motor output and the other near the output shaft of the actuator.

2 User Interface

Configuration interface is via a *Bluetooth* wireless connection to Rotork Enlight software. In addition, each actuator has a tri-colour status LED located at the top of the rotary selector.

3 Reserve Powerpack / Power Supply

Incorporated within each AC actuator is a switch mode power supply, which can accept a range of input voltages from 100–240 VAC 50/60 Hz. An optional 24 VDC supply can be catered for. For fail-to-position action on loss of supply, the CVA can be fitted with an optional reserve powerpack, which consists of 'super capacitors'. The reserve powerpack will allow the actuator to move to a predetermined position on power failure.

4 DC Brushless Motor

The CVA uses a high efficiency, continuous rated, brushless DC motor. This allows maintenance free operation even with continuous unrestricted modulation duty.

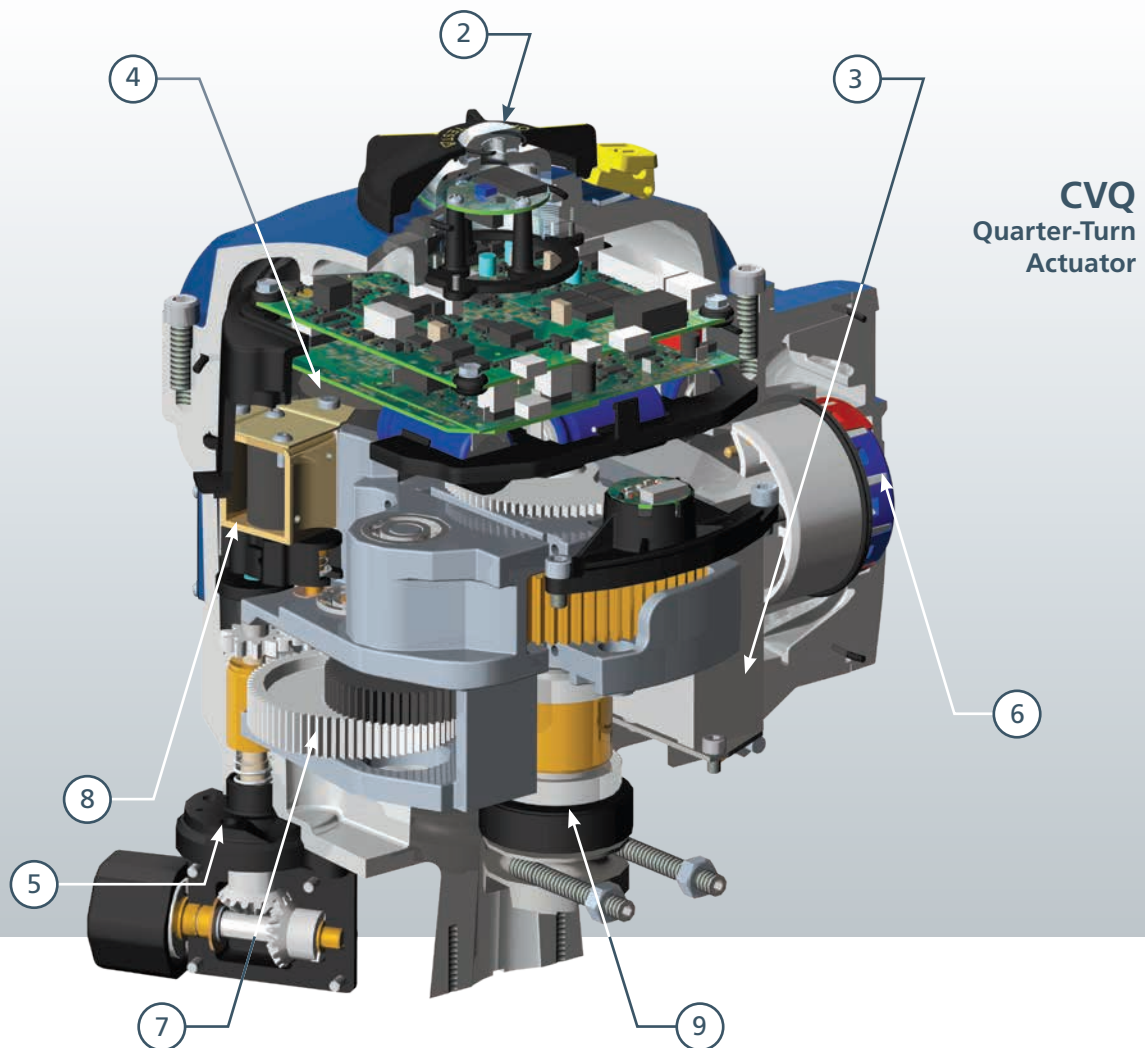

CVQ
Quarter-Turn
Actuator

5 Hand Drive

Optional hand drive mechanism can be provided with both linear and quarter-turn actuators to allow manual operation of the valve.

6 Terminal Bung - Double-Sealing

The “double-sealed” terminal compartment provides a compact wiring interface for power, control and feedback indication. Four conduit entries are provided as standard with internal and external earth connection points. Control and indication circuits can be supplied certified to “IS”. Double-sealing is important as the terminal compartment is then segregated by a watertight seal from the rest of the actuator. Even if the cover is left off during installation or conduit entries for cable glands are not properly sealed, the actuator remains fully protected.

7 Geartrain

Simple yet durable high efficiency spur gear drive, lubricated for life with proven high reliability.

8 Anti Back-Drive Mechanism

The CVA standard build is capable of resisting any back drive from the valve up to 125% of the rated force. For applications where loss of power requires increased “fail-in-position” capability, an optional solenoid locking mechanism is available.

9 Output Drive

For CVQ the base conforms to MSS SP-101 or ISO 5211. CVL may be adapted to suit individual valves.

Control & Monitoring

In the demanding process environment it is important to have flexibility of control to meet both design control requirements and operational requirements. The new Rotork CVA actuator offers a comprehensive range of control options that can be tailored to meet process control requirements.

The standard CVA provides for 4 to 20 mA analogue control and position feedback. In addition, options are available to allow interfacing with Pakscan, HART, Profibus or Foundation Fieldbus network control.

CVA setup is non-intrusive using wireless *Bluetooth* comms between the actuator and a PDA running CVA Enlight software - available for free download at www.rotork.com

In addition to I/O parameterisation, CVA direction to open/close and action on loss of signal can be user configured along with input characterisation for valves with non-linear flow characteristics. Independent open/close settings for thrust/torque force applied and valve seating action are available. A configurable contact indicating actuator availability, position etc. is provided as standard.

Operating Modes

There are 3 modes of operation available for the CVA, each set by the rotary selector on the top of the actuator. The selector is non-intrusive using magnetic hall effect sensors and can be padlocked in the required position.

In the centre of the selector there is a tri-coloured green, blue and red indicator LED which is used to indicate status:

- Green – Run mode status
- Blue – *Bluetooth* communications
- Red – Alarm status

Full details of LED status indication are provided in the CVA Installation and Maintenance manuals PUB042-003 (Linear) and PUB042-004 (Quarter-Turn).



The operating mode selector has 3 positions:

- “Run”: The normal operating mode of the CVA. The actuator responds to the process demand signal being used for control.
- “Stop”: Electric operation including fail-to-position operation is prevented.
- “Test”: This is an auto-test carried out by the CVA used as a quick method for testing the CVA’s ability to control its output independently of the external control system. The auto-test routine performs a series of step and cycle routines centred on the last demand position. On completion of the test the results are indicated and “Run” control may be re-selected. If this test function is not required it can be disabled using the Enlight software. During the test, the following parameters are measured:

Deadtime; T86* = Step response time; Settling time; Average force in each direction of travel; Full stroke speed; Valve friction.

Based on the results, the LED will fast-flash for 10 seconds either GREEN for “all parameters within acceptable limits” or RED for “one or more parameters outside of acceptable limits”. Enlight can be used to interrogate the actuator for details of the test results.

Valve Control

The stroke may be set up using a “quick setup” function where the actuator automatically moves to open/close valve stops and sets the limit positions. Manual setup is also available for limited stroke applications.

The following user configurable settings are available:

- Stroke – CVL: Available up to that defined by the size (refer to performance 1.1 page 19). Maximum resolution achieved at full CVL mechanical stroke.
- Stroke – CVQ: Up to 90° +10°. Maximum resolution is achieved at 90° rotation.
- Direction to close: CVL extend or retract. CVQ clockwise or anticlockwise.
- Valve stop action: Limit – moves to a set limit position or force – seats the valve to a user set force.
- Thrust/torque limitation: 40% and 100% of actuator rated thrust/torque.
- Output speed: Speed is automatically controlled as a function of the distance to travel to the demand position. The larger the error and bigger this distance, the faster the operation. On approaching the demand position, the motor is controlled to decelerate and creep to the demand position therefore preventing overshoot. The default speed setting is optimised for performance, however the speed can be adjusted if required within the range 5% to 100%.

*For a full definition of T86 refer to page 30.

Control & Monitoring

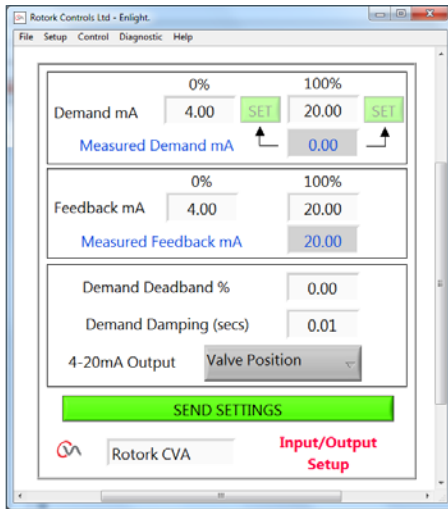

CVA Enlight Input Output Setup

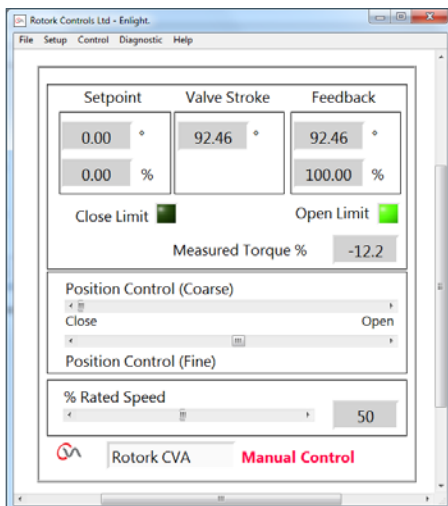

CVA Enlight Manual Control

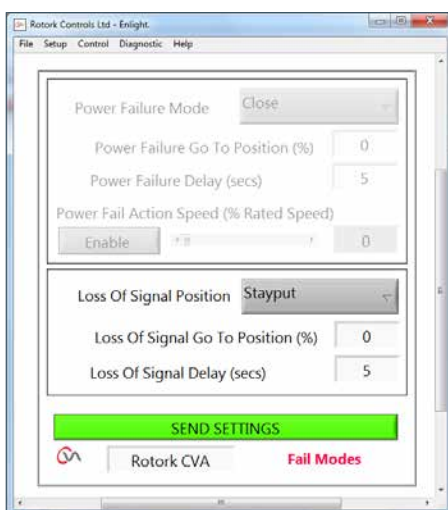

CVA Enlight Fail Mode Setup

4 to 20 mA Control

Opto-isolated loop powered 4 to 20 mA control is provided – optional Intrinsically Safe input is available. A user configurable function is available, which allows a non-linear relationship to be set between the demand signal and actuator demand position. This setup would typically be used to characterise the valve response – refer to Input Characterisation, page 12.

Specification:

- Resolution: Minimum change in demand signal required for guaranteed response: $\geq 0.1\%$ of input signal range.
- Linearity: $\leq 0.5\%$ full scale.
- Optional Intrinsic Safety: 4 to 20 mA loop powered circuit can be supplied Intrinsically Safe “ia” (2 independent faults). Input terminals are segregated and protected with a cover.

User Settings:

- Range Selection: 4 to 20 mA or 20 to 4 mA, full or partial stroke.
- Demand Deadband: 0% - 10% in 0.1% increments.
- Demand Damping: Designed to reduce response to demand signal noise or instability.
- Signal Loss Action: Close, Stayput or Open. Threshold for “lost signal” is < 2 mA.
- Characterisation: Default is linear, pre-configured. Equal percentage and quick opening characteristics can be selected in addition to user configurable, 21-point characterisation array.

4 to 20 mA Feedback

An opto-isolated loop powered 4 to 20 mA output is provided for user feedback – optional Intrinsically Safe output is available. This can be configured to provide valve position or measured thrust/torque force applied. A user-configurable function is available allowing a non-linear output to be set in parallel with a characterised control form - refer to Input Characterisation, page 12.

Specification:

- Resolution: Minimum change in position/thrust required for feedback signal change: $\geq 0.1\%$ full scale.
- Linearity: $\leq 0.5\%$ full scale.
- Optional Intrinsic Safety: 4 to 20 mA loop powered circuit can be supplied Intrinsically Safe “ia” (2 independent faults). Input terminals are segregated and protected with a cover.

User Settings:

- Range Selection: 4 to 20 mA or 20 to 4 mA - auto scales to set limits.
- Characterisation: On/Off. When selected “on” the feedback signal will apply the same characterisation as set for control.

Control & Monitoring

Input Characterisation

Many control valves have non-linear flow characteristics that require a non-linear output in response to a linear input. As standard, the CVA output can be characterised to meet process requirements using the Rotork Enlight software. There are three preset characteristics that can be selected from a drop down box; linear (default); equal percentage and fast opening.

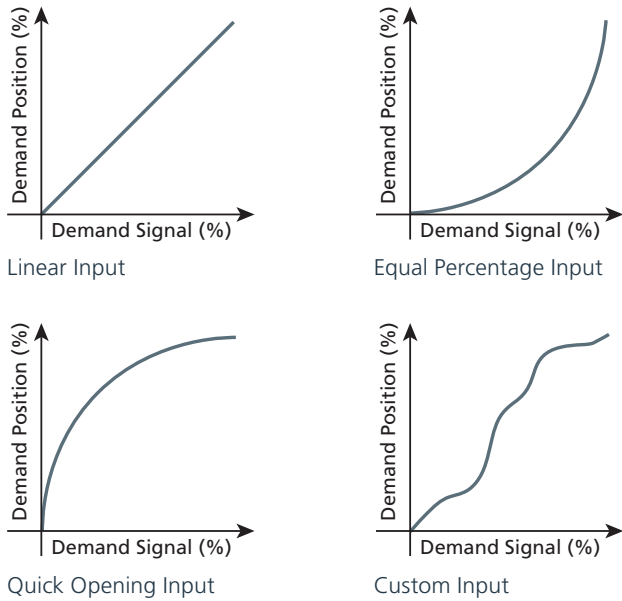

Input Characterisation Graphs.

In addition it is possible for a custom, user defined non-linear “transfer function” between the demand signal and valve position to be configured. This is achieved by entering 21 valve positions with their corresponding demand signal values. Interpolation between entered values is linear.

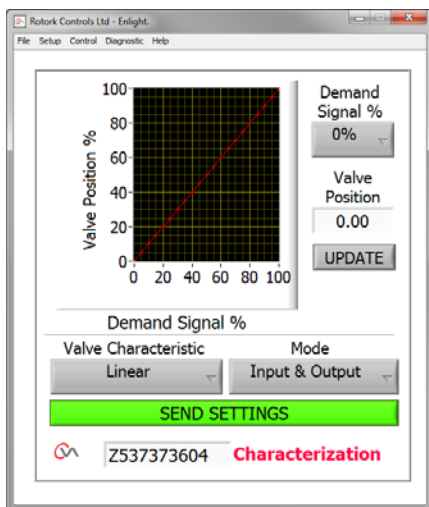

Input Characterisation

Status Indication Relay

A user configurable relay with a single pole, volt free, normally open contact is provided for status and availability indication. A list of configured settings is provided below. The contact is rated at 8 A / 120 VAC / 30 VDC.

Function	Description
Availability	Active when the CVA is capable of being remotely controlled. - Actuator is in Remote Mode. - Actuator has no faults which would prevent operation.
Fault	Active with any detectable fault within the actuator or valve.
Open Limit	Active when the actuator is at the fully open position.
Closed Limit	Active when the actuator is at the fully closed position.
Opening Force Limit exceeded	Active when the actuator has reached the set opening operating force limit.
Closing Force Limit exceeded	Active when the actuator has reached the set closing operating force limit.
Force Limit exceeded	Active when the actuator has reached either the set opening or closing operating force limits.
Fail-to-Position	Active when the actuator is performing its fail-to-position action.
Intermediate Position	Active if the actuator passes an intermediate position. Any position to a 1% resolution and in the close or open direction.

Hardwired Discrete Control

For discrete hardwired control, the optional RIRO (Remote In Remote Out) can be fitted. The option allows the user to hardwire a discrete digital control (24 VDC nominal or 120 VAC nominal) for open and close operation. The option also allows up to four extra relay contacts to be available.

For full information and specification, please refer to publication PUB042-002.



HART®

HART (Highway Addressable Remote Transducer) is a communication protocol based upon the Bell 202 telephone communication standard and uses the FSK (frequency shift keying) principle. The signal consists of two parts, the analogue 4 to 20 mA current loop and a superimposed digital variable frequency signal - see Fig. 4.

Traditionally the 4 to 20 mA loop is used for control and the superimposed digital signal for feedback and configuration. The CVA utilises the signals in this way. Setup and operation for the 4 to 20 mA signal is the same as for the standard 4 to 20 mA control. Configuration and feedback using the HART digital signal can be achieved using the host connected to the CVA to select the parameters required.

The majority of the CVA user configurable settings can be made over the HART communication protocol. In addition to this the following HART parameters can also be adjusted: -

- HART Tag
- Address
- Device ID
- Date Code

Foundation Fieldbus®

Foundation Fieldbus has become widely accepted for use in process control systems. Its primary feature is the ability to distribute control away from the central DCS. The Rotork Foundation Fieldbus interface card connects directly onto the standard Foundation H1 bus system. The function blocks embedded in the module cover the control and monitoring of the valve and actuator.

Using the certified Device Description files, the Foundation Fieldbus interface card is simple and easy to use. The ability to report extensive actuator feedback within a single input block as well as system diagnostic information, makes Rotork the first choice for use with a Foundation Fieldbus system.

- Foundation ITK inter-operability certified
- Fully compliant with IEC61158-2 standard
- Includes Link Master and LAS capability
- Independent HIST approval by major DCS vendors
- Full H1 field capability

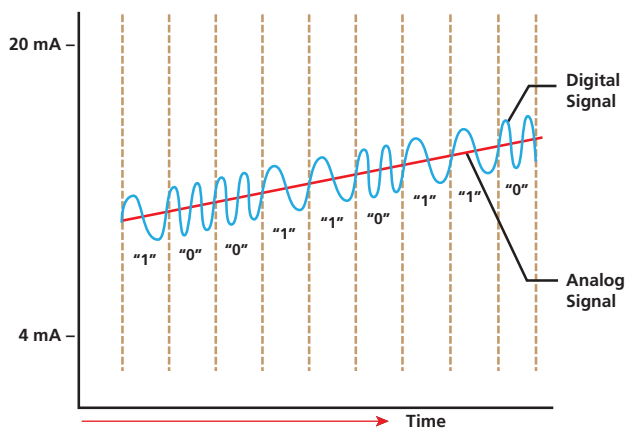

Figure 4: FSK Principle (source: HART®)



Profibus®

Profibus is a leading international network protocol for high speed data communications in industrial automation and control. The Rotork Profibus DP interface card provides comprehensive control and feedback data about the valve and actuator using DP-V0 cyclic communications whilst extended actuator diagnostics and configuration is included in the DP-V1 acyclic data supported by this module.

EDD and DTM files allow the Rotork device to be incorporated into asset management systems giving access to performance critical parameters, whilst the independently certified GSD file guarantees device interoperability.

Rotork offer multiple configuration options within the GSD file to enable a choice of data collection.

- RS485 Profibus DP V0 and V1 compliant
- Fully meets IEC61158-3 standard
- Profibus PNO certified
- Supports speeds up to 1.5 Mbit/s



Pakscan™ P3 (2-wire) System

The Rotork *Pakscan* system is a world leader in flow control automation. First launched in 1986, *Pakscan* has been at the forefront of network technology since its inception, helping to control over 100,000 actuators worldwide.

Pakscan network systems offer the customer unrivalled control, reliability and support. This is backed-up by a worldwide service and support network to help keep your plant running 24 hours a day, 7 days a week.

The *Pakscan* system provides the vital link between valve actuators and supervisory control. It is an intelligent, reliable, high integrity, fast and easy to install network between field equipment and the control room, designed specifically for use with Rotork products.

- Defined transaction times based on cable parameters and length
- Automatic cable monitoring and fault isolation
- Field cable fault tolerant
- Fully pre-programmed master station
- Master station with HMI Screen, keypad and built-in web server for full system diagnostics
- Hot standby master station capability
- Easily expanded
- Simple Modbus RTU (RS232/RS485) / TCP (Ethernet) host communications
- Field and host communication diagnostics and data logging
- Commission without the need for a host DCS or PLC
- Proven track record
- Over 100,000 installed nodes
- Multiple host connections supported
- Network with the capacity for up to 240 actuators on a single 20 km 2-wire loop

See publication PUB059-030 for further details.

Modbus®

Modbus®

Modbus remains the most popular process communication protocol in use today with the widest acceptance and highest number of applied systems of any automation protocol. Rotork's Modbus interface card allows actuators to be connected to a 2-wire RS485 network for direct communication to a PLC or DCS using Modbus RTU protocol.

The resulting network is able to monitor and control the connected actuator. As the Modbus protocol is so simple the system engineer has full control over the data flow on the highway and the information to be collected and controls implemented. There are no complications with device description files or special programming tools required when setting up a Modbus system.

- RS485 2-wire RTU communication
- International open standard
- Single and Dual redundant options
- Integral Repeater modules included where necessary
- Up to 115 kbps

RIRO

Hard Wired Discrete Control

For discrete hardwired control, the optional RIRO (Remote In Remote Out) can be fitted. The option allows the user to hardwire a discrete digital control (24 VDC nominal or 120 VAC nominal) for open and close operation. The option also allows up to four extra relay contacts to be available for various functions.

Performance Logging

Lifetime Support

Rotork understands its customers' needs for back up support. The costs and penalties of plant downtime, delayed commissioning schedules and inappropriate maintenance are too high to allow for inefficient support.

With *Bluetooth* wireless communication and the onboard datalogger, the CVA offers the ability to provide complete product back up with analysis and configuration. With Rotork's unrivalled worldwide service, expert advice is always close to hand.

Remote

The CVA utilises *Bluetooth* wireless communication for fast, safe, non-intrusive data exchange. Actuator setup configuration can be analysed and, if required, easily changed. As every CVA includes an onboard datalogger, operational data such as valve torque profiles, actuator events and statistics can be downloaded for detailed investigation. After analysis any changes to the actuator setup configuration can be relayed back to the actuator.

The actuator commissioning software enables parameters to be downloaded into a user-friendly report, allowing the customer to view data on printed format, on screen, or electronically for maintenance records.

COMMISSIONING REPORT			
Report Generated By:	AMC/AMC	Report Generated:	
Commissioning Date:	04/05/2014	Commissioning Ref No.:	
Valve Details:	2" Valve 02-001	Main Commissioning Ref:	
Commission Ref No.:	001		
Main Commissioning Ref:	001		
Actuator Serial Number:	00000001	Valve Type:	Pressure Controller
Actuator Type:	02-001	Pressure Controller:	02-001
State of Manufacture:	02-001	Valve Details:	2" Valve 02-001
Direction of Travel:	Open to Close	Valve Function:	Automatic
Open Load Limit:	Open to Close		
Close Load Limit:	Open to Close		
Open Load Limit:	0%	Minimum Load (Pilot):	No
Close Load Limit:	0%	SPV Pilot:	No
Event:		Minimum Load (Pilot):	No
		Minimum Load (Pilot):	No
Commissioning Serial No.:	00000001		
SPV Serial No.:	00000001		
Position Controller Serial No.:	00000001	Pressure Load Threshold:	0%
Manual Controller Serial No.:	00000001	Position on Pilot Load:	0%
Load Controller Serial No.:	00000001	Position on Pilot Load:	0%
SPV Serial No.:	00000001	Signal Load Threshold:	0%
Manual Serial No.:	00000001	Minimum on Signal Load:	0%
Optimiser Serial No.:	00000001	Position on Signal Load:	0%
Optimiser Serial No.:	00000001		



Pocket Enlight

CVA Enlight PDA software is a graphical user interface allowing all CVA setup configuration and datalogger information to be reviewed, analysed and reconfigured. This visually interactive application is a stand-alone programme, running on Microsoft Windows™ Mobile O/S. Intuitive controls make analysing the data from a CVA fast and simple.

Alternatively, data can be uploaded from the actuator and later downloaded to a PC.

Rotork Help - Online

Rotork has a comprehensive worldwide service network to provide you with local support wherever you are. Rotork trained technicians working from our network of offices and centres of excellence are available to offer immediate assistance. To contact Rotork, visit www.rotork.com

Valve Diagnostics

A datalogger is provided, which helps detect potential valve problems before a failure occurs. The datalogger stores operational data relating to the valve position and load, which can be monitored over time.

Typically, after installation, an actuator and valve snapshot will be recorded which may be used for comparison at a later date. Comparison may be either through human analysis or through automatic alarm level tripping.

Datalogging Parameters

The following parameters are recorded in the CVA datalogger's non-volatile memory. Some of these parameters can be analysed using the Pocket Enlight, however detailed analysis can be carried out by a desktop PC.

Data recorded by Datalogger

- Dwell time and force profiles
- Minimum and maximum thrust measurements at each 1% of travel
- Force reference profile
- Number of direction changes (cycle counter)
- Total accumulated travel distance
- Event log
- Actuator temperature

Diagnostic Data

- Dynamic response tests
- Step change tests
- Reserve power pack energy estimate
- Internal diagnostics
- Configuration change log
- Number of fail-to-position operations

Performance Logging

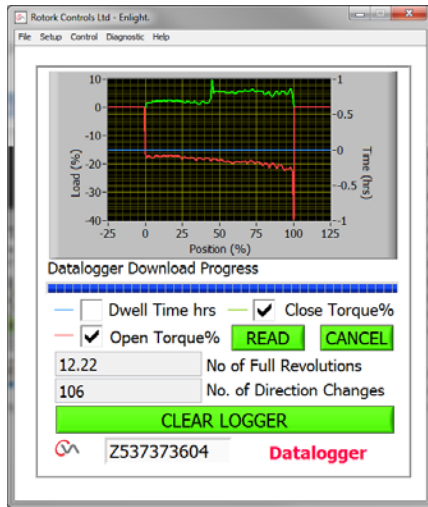

Datalogger View

Dwell Time Logging

The total accumulated time spent within each 1% portion of stroke is recorded by the CVA datalogger. This data may provide essential information regarding the valve sizing, control loop tuning and process stability.

For example, a valve sized for a specified process requirement to provide optimum control ranging around the 50% position should have a dwell time characteristic idealised in the graph below. Offsets towards the open or closed positions may indicate under or oversizing of the valve or process conditions outside design specification. A broad characteristic may confirm significant process rangeability or indicate instability. Coupled with other process data, valve dwell time can provide information leading to improved efficiency and production.

A reference dwell profile can be recorded shortly after the installation of the actuator to be used to check for sizing and stability. This may then be used for comparison in the future.

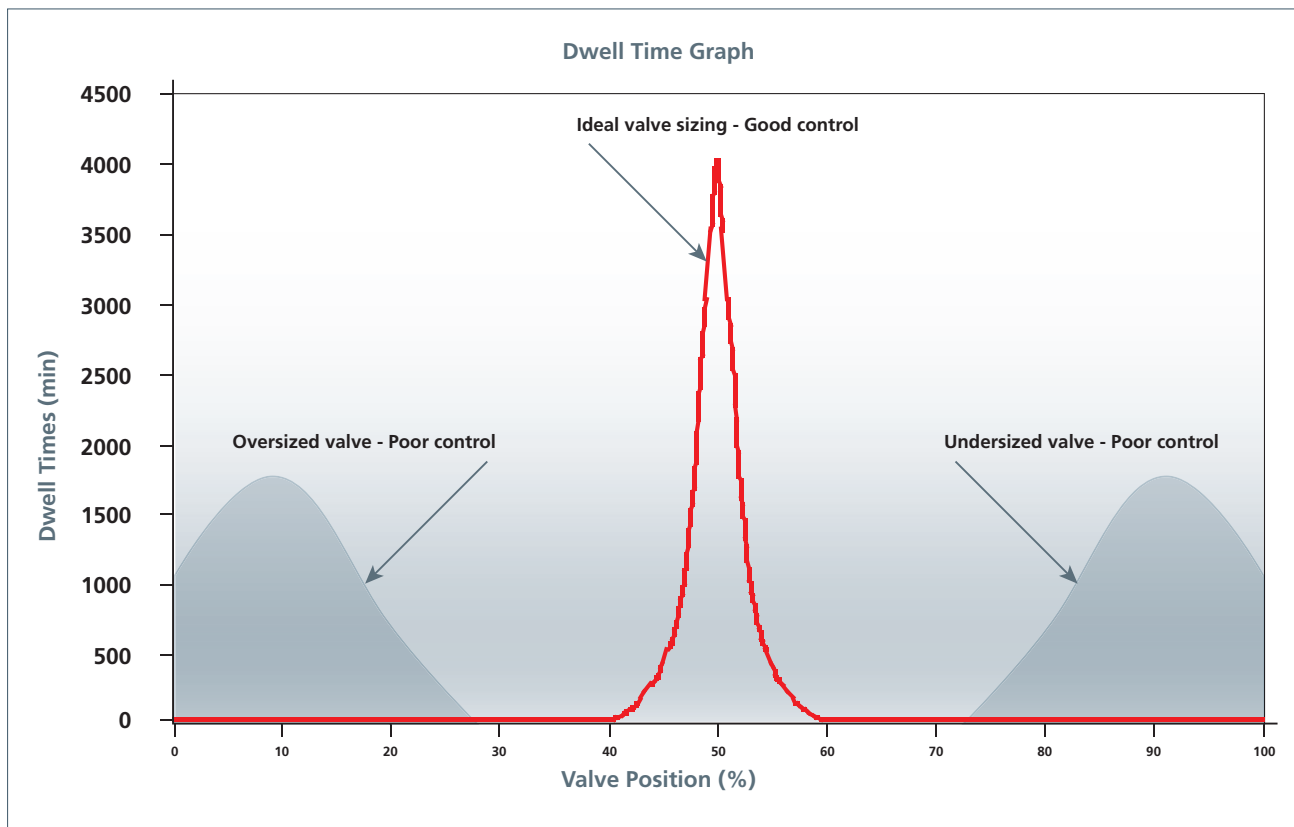



Actuator Specification

The following pages contain details on performance and specification for the Rotork CVA range of actuators.

Please use the following contents table to help access the information you require.

1	Performance Summaries	19
1.1	Mechanical Performance	19
1.2	CVA Electrical Power Consumption	20
1.3	Positioning Control Performance	20
1.4	Position Feedback Performance	20

Standard Specifications - CVL & CVQ

2	Standard Specification	21
	Introduction	21
2.1	Enquiry Datasheet	22
3	CVL General Dimensions	23
4	CVQ General Dimensions	25
5	Design Specifications	27
5.1	Duty Rating	27
5.2	Design Life	27
5.3	Vibration, Shock and Noise	27
5.4	Operating Temperature	27
6	Non-Hazardous & Hazardous Certified Enclosures	28
6.1	Non-Hazardous Area Enclosures	28
6.2	Hazardous Area Enclosures	28
7	Regulatory Standards	30
8	Paint Finish	30



Performance Summaries

1 Performance Summaries

1.1 Mechanical Performance

The rated force (thrust or torque) for each size of actuator is detailed below. The minimum settable force is 40% of the maximum rated. Operating time tolerance +/-10%.

Measurement of force has an accuracy of +/-5% of unit rated force.

The CVA can resist back driving forces from the valve up to 125% of rated without movement. An optional lock mechanism prevents back drive to 300% of rated force. All CVA actuators are factory calibrated.

CVL - Linear

Model	Min Thrust	Rated Thrust*	Max Stroke	Speed	Full Stroke Time (sec)
CVL-500	200	500	1.5	0.25	6
	890	2,224	38.1	6.35	
CVL-1000	400	1,000	2	0.1	20
	1,780	4,448	50.8	2.54	
CVL-1500	600	1,500	2	0.1	20
	2,669	6,672	50.8	2.54	
CVL-5000	2,000	5,000	4.5	0.1	45
	8,869	22,241	114.3	2.54	

Lbf - inches - inches/second
Newtons - mm - mm/second

*Corresponds to 100% thrust sensor setting. Minimum thrust corresponds to 40% thrust sensor setting.

CVQ - Quarter-Turn

Model	Min Torque	Rated Torque	Operating Time* (sec)
CVQ-1200	480	1,200	15
	54.2	135.5	
CVQ-2400	960	2,400	20
	108.4	271	

lbf.in
Nm

*Corresponds to 100% torque sensor setting.
Minimum torque corresponds to 40% torque sensor setting.
Note: Mechanical stop adjustment: +/-5%.



Performance Summaries

1.2 CVA Electrical Power Consumption

CVA is designed to be very efficient with very low power consumption.

The relatively low power consumption measured during modulation (continuous 2 Hz, 2% cycling test) is due to the inertial energy in the motor being converted back to electrical energy and stored. This energy can then be used to accelerate the motor in the opposite direction.

If the reserve powerpack option is fitted, charging of the super capacitors will take place on power up. The LED will flash during charging and operation is inhibited during charging. Charging times are listed in the table below.

refer to the CVA Electric Motor Performance Data document PUB042-010.

Model	CVL-500	CVL-1000	CVL-1500	CVL-5000	CVQ-1200	CVQ-2400
Charge Time (sec)	30	100	100	300	100	200

1.3 Positioning Control Performance

The following control positioning performance is based on a 4 to 20 mA control system with CVA operating over its maximum stroke, rated speed and constant force with

minimum deadband set and with a linear demand/valve characteristic. Resolution is defined as: minimum change in input signal required for guaranteed response.

4 to 20 mA Control - Positioning: % demand signal range

Resolution	≥ 0.1%
Linearity	≤ 0.5%

1.4 Position Feedback Performance

The following position feedback performance is based on CVA operating at maximum stroke with a linear characteristic set. Feedback calibration is automatic to the set limit positions.

Resolution is defined as: minimum change in position/thrust required for feedback signal change.

4 to 20 mA Feedback - % feedback signal range

Resolution	≥ 0.1%
Linearity	≤ 0.5%

Ultimate performance will be determined by the process, valve and control system.



Standard Specifications

2 Standard Specification

Introduction

CVA range actuators are self contained, purpose designed and built for continuous remote electrical operation of control valves. Comprising an electric motor, reduction gearing, motor controller with travel and thrust/torque limitation, electronic logic controls and monitoring facilities – housed in a double-sealed watertight enclosure. Hazardous area certified enclosures meeting international and national requirements are also available.

All thrust/torque and position settings as well as configuration of the actuator are made using a non-intrusive *Bluetooth* device. *Bluetooth* software is available for free download from www.rotork.com

Enclosure requirements and build options selected must be specified with the enquiry.

The example enquiry datasheet on page 22 provides an outline of the basic information required for quotation. Where there is a project, framework or job specification applicable, Rotork will be pleased to analyse it in detail.

It is not necessary to specify the actuator type or size – Rotork will provide the most cost effective solution based on the information provided.



Standard Specifications

2.1 Enquiry Datasheet

Page	Requirement	Options	Detail
19	Valve Type	Quarter-turn	° Rotation
		Linear	Stroke length (in/mm)
27	Duty Cycle	Modulating starts / hour	Specify number or "continuous"
19	Operating Time	(°-in-mm/sec)	Specify
19	Seating Torque/Thrust	Nm (lbf.in) / N (lbf)	Specify
19	Modulating Torque/Thrust	Nm (lbf.in) / N (lbf)	Specify
27-29	Temperature Range	Standard and Low	Refer to p24-26 for details
20	Power supply	1-phase —Volts —Hz	Specify
		DC	24 Volts DC only
7	Fail-to-Position on loss of main power	Not required	
		Close	
		Stayput	
		Open	
		Intermediate %	
7	Intrinsically Safe I/O	Yes	
		No	
28	Enclosure	Non-hazardous	IP / Nema rating
		Hazardous	
10-14	Remote Control/Indication	4 to 20 mA	
		HART	
		Profibus	
		Foundation Fieldbus	
		Pakscan	
		Modbus	
		RIRO	
9	Manual Override	Yes	
		No	
	External Switches	Specify	
	External Position Indication	Specify	
	Topworks	Specify	

Standard Specifications

3 CVL General Dimensions

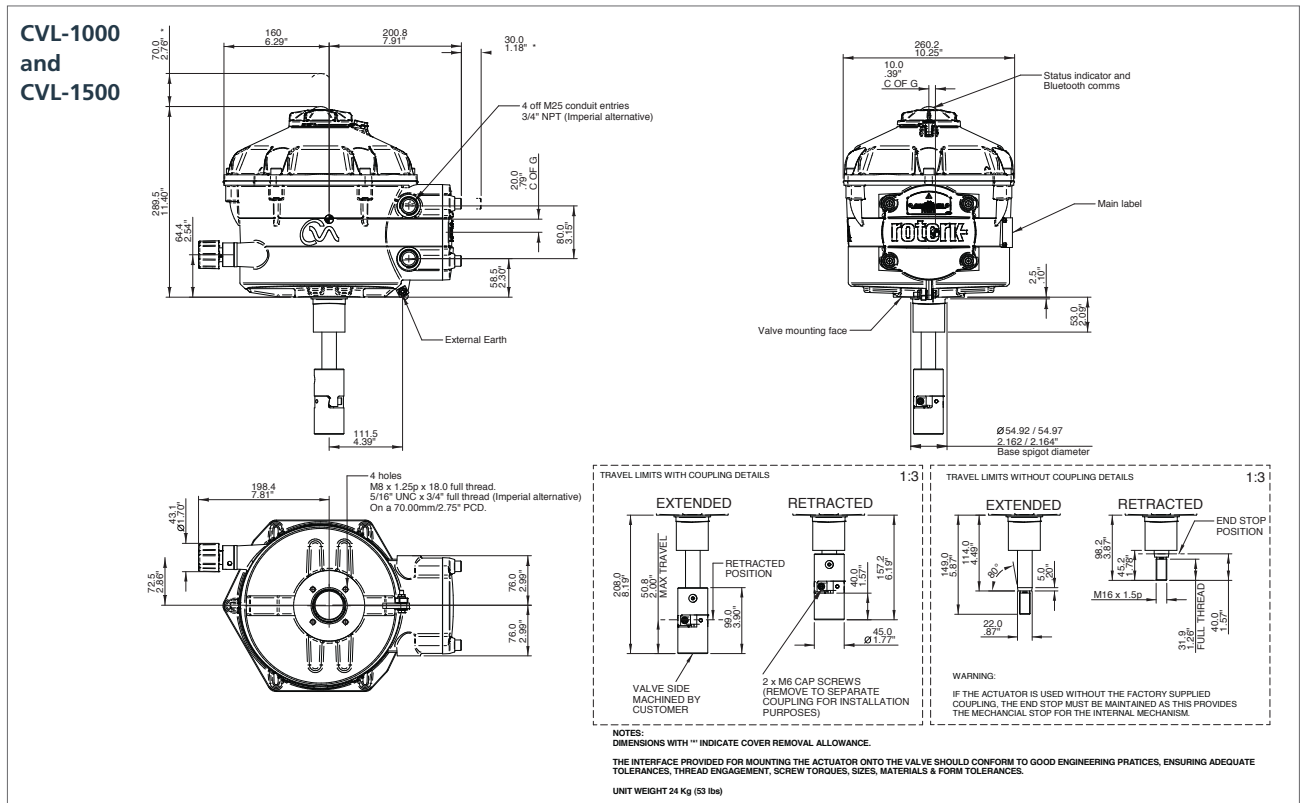
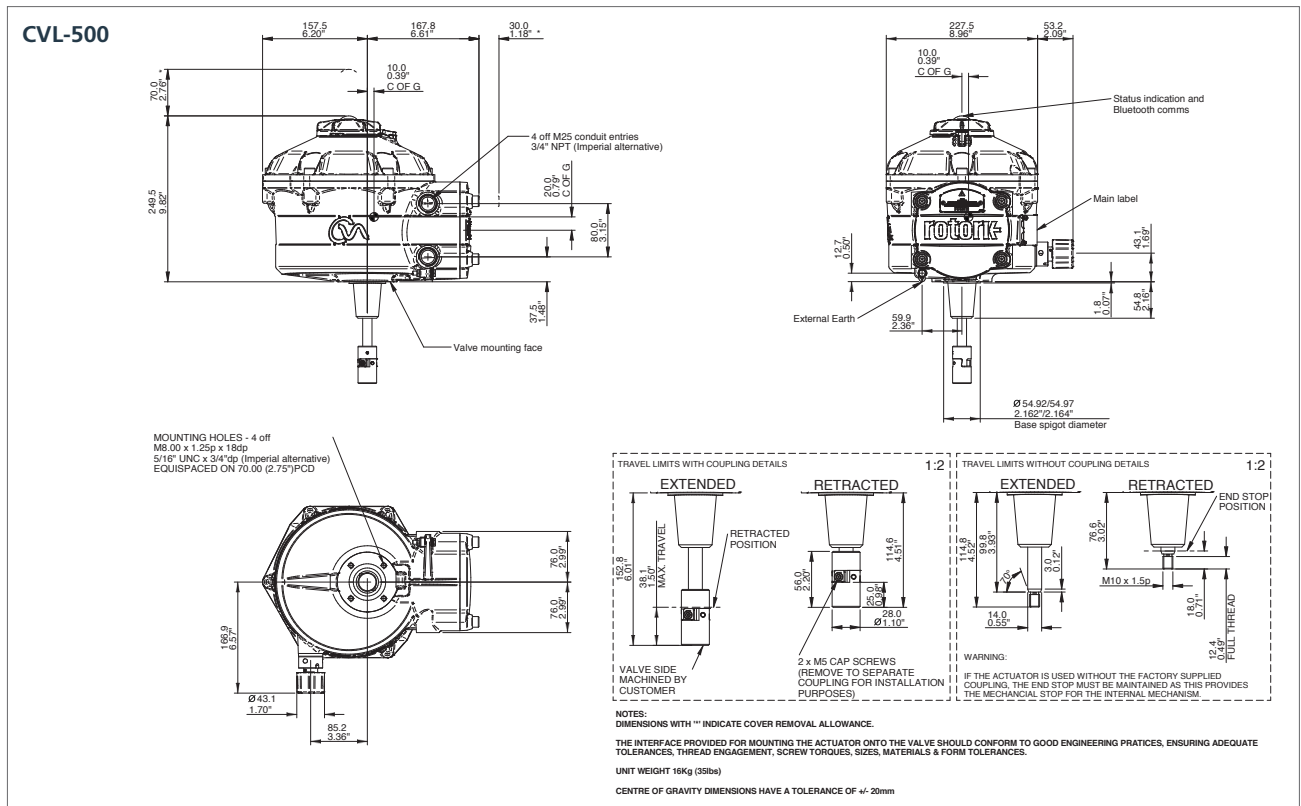

NOTES: Dimensions with "*" indicate cover removal allowance. CVL-500 Unit weight approximately 16 kg (35 lbs). CVQ-1200 unit weight approximately 18 kg (40 lbs). The interface provided for mounting the actuator onto the valve should conform to good engineering practices, ensuring adequate tolerances, thread engagement, screw torques, sizes, materials & form tolerances

Standard Specifications

3 CVL General Dimensions

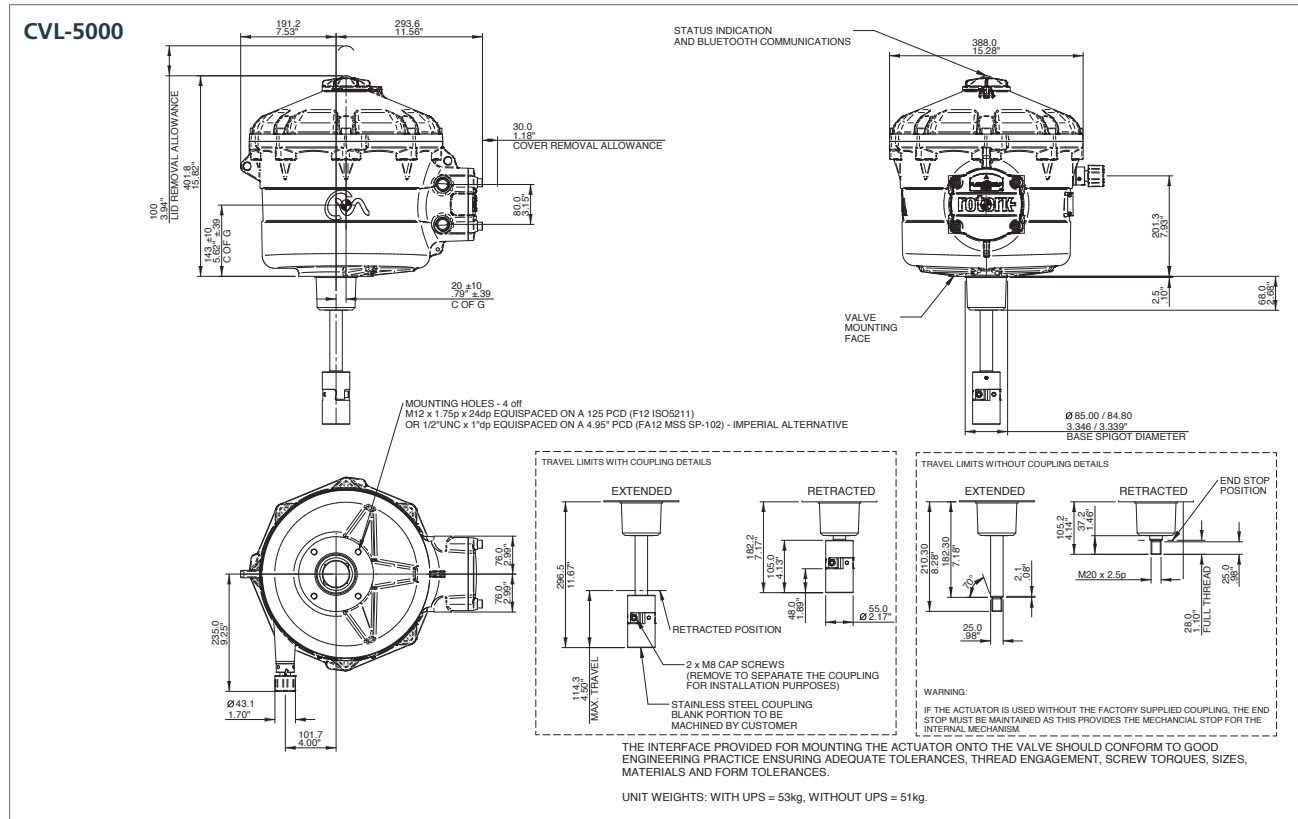

Standard Specifications

4 CVQ General Dimensions

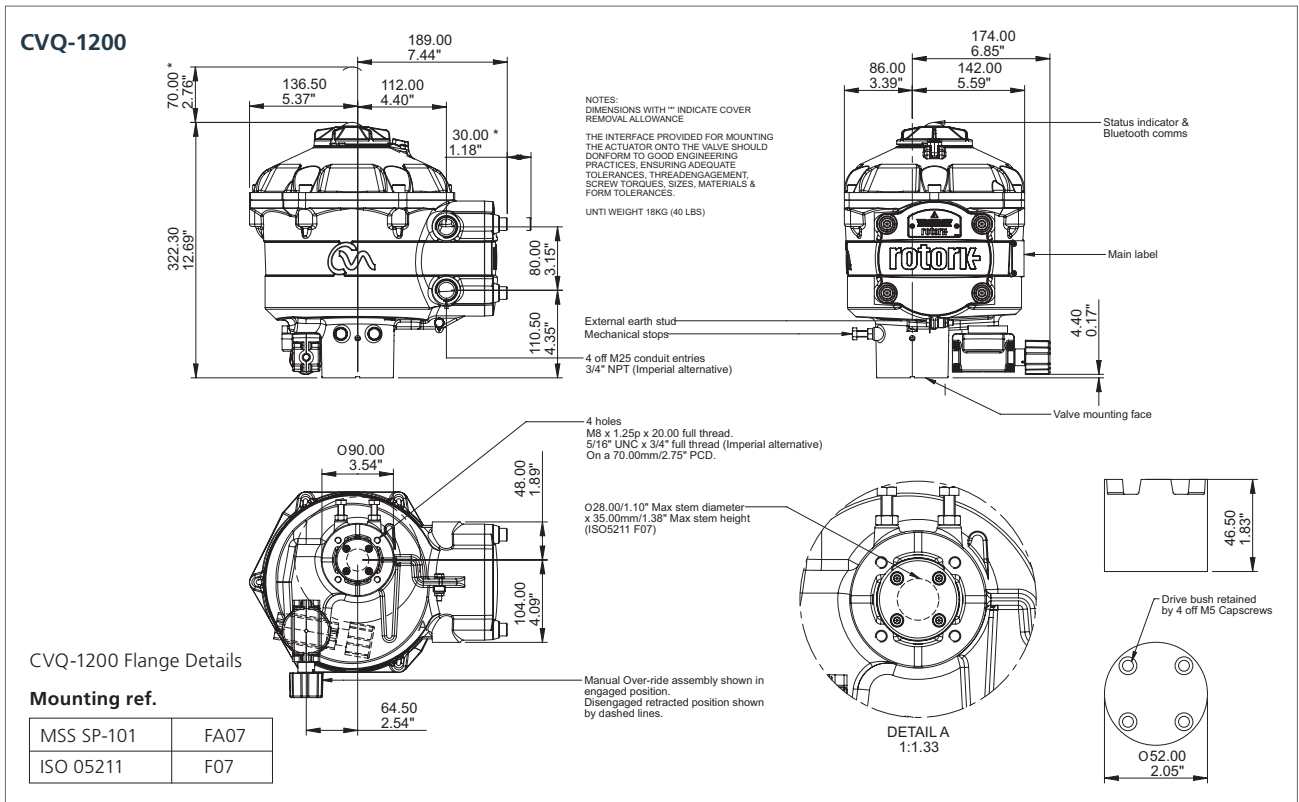

Standard Specifications

4 CVQ General Dimensions

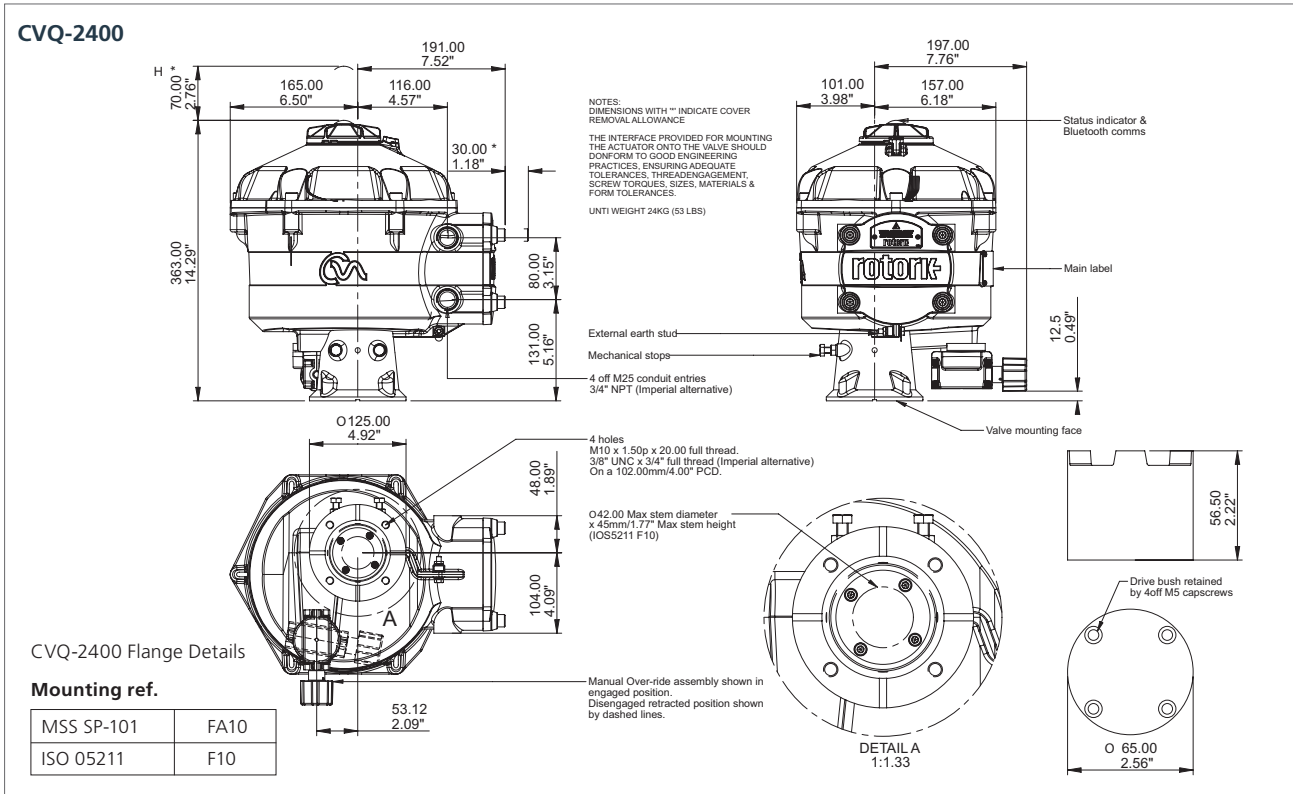

NOTES: Dimensions with "*" indicate cover removal allowance. CVL-1500 Unit weight approximately 24 kg (53 lbs). CVQ-2400 unit weight approximately 24 kg (53 lbs). The interface provided for mounting the actuator onto the valve should conform to good engineering practices, ensuring adequate tolerances, thread engagement, screw torques, sizes, materials & form tolerances



Standard Specifications

5 Design Specifications

5.1 Duty Rating

Duty Classification	Actuator Type	Rating
Modulating	CVL / CVQ	S9 – Duty with non-periodic load and speed variations, capable of continuous unrestricted modulation.

5.2 Design Life

Duty Classification	Actuator Type	Size	Minimum Design Life Rating	
			Millions of 1% strokes at 75% load cycles simulating realistic application conditions*	Millions of 10% strokes at 100% load cycles
Modulating	CVL	CVL-500	40	20
		CVL-1000	12	6
		CVL-1500	12	6
		CVL-5000	5	2.5
Modulating	CVQ	CVQ-1200	16	8
		CVQ-2400	12	6

* Testing uses a 1% dither at 75% load that changes position periodically based on a normal distribution pattern around the nominal 50% position.

5.3 Vibration, Shock and Noise

CVA actuators are suitable for applications where vibration and shock severity does not exceed the following:

Type	Level
Plant induced vibration	1 g rms total for all vibration within the frequency range of 10 to 1,000 Hz.
Shock	5 g peak acceleration.
Seismic	2 g acceleration over a frequency range of 1 to 50 Hz if it is to operate during and after the event. 5 g over a frequency range of 1 to 50 Hz if it is only required to maintain structural integrity.
Emitted noise	Independent tests have shown that at 1 m generated noise does not exceed 61 db(A).

Levels quoted are those present at the actuator mounting interface.

It should be noted that the effects of vibration are cumulative and therefore an actuator subjected to significant levels may have reduced life.

5.4 Operating Temperature

CVA actuators are suitable for operation within the ambient temperature ranges shown below. Refer to section 6.2 for hazardous area certification operating temperature restrictions. For temperatures outside this range please contact Rotork.

Actuator Type	Standard Temperature*	Low Temperature Option*
CVL / CVQ	-30 to +70 °C (-22 to +158 °F)	-40 to +60 °C (-40 to +140 °F)

*Hazardous Area certification determines permissible operating temperature range. Refer to section 6.

Standard Specifications

6 Non-Hazardous & Hazardous Certified Enclosures

All CVA actuator hazardous and non-hazardous area enclosures are watertight to IP68/NEMA 4 & 6.

Through the use of wireless *Bluetooth* commissioning and adjustment, covers never need removing and therefore the hermetic, factory-sealed enclosure protects internal components for life. The terminal compartment is sealed from other areas by the Rotork double-seal, maintaining watertight integrity even during site connection when terminal cover is removed.

CVA actuators are available with the following enclosure types for which the ambient working temperature ranges are stated. Where option temperatures are indicated, changes to some actuator components are required and therefore the temperature requirement must be specified. Hazardous area approvals for other country standards are available; please contact Rotork.

6.1 Non-Hazardous Area Enclosures

WT: Standard Watertight

Standard	Rating	Standard Temperature	Low Temperature Option
BS EN 60529 (1992)	IP68 – 7 metres / 72 Hrs	-30 to +70 °C (-22 to +158 °F)	-40 to +60 °C (-40 to +140 °F)
NEMA (US)	4 & 6	-30 to +70 °C (-22 to +158 °F)	-40 to +60 °C (-40 to +140 °F)
CSA (Canadian)	4 & 4X	-30 to +70 °C (-22 to +158 °F)	-40 to +60 °C (-40 to +140 °F)

6.2 Hazardous Area Enclosures

CVA range actuators are built in accordance with the following standards:

European Hazardous Directive - ATEX

Directive/Standard	Rating	Standard Temperature	Low Temperature Option
II 2GD	Exd [ia] IIB T4	-20 to +60 °C (-4 to +140 °F)	-40 to +60 °C (-40 to +140 °F)
II 2GD	Exd [ia] IIC T4	-20 to +60 °C (-4 to +140 °F)	-40 to +60 °C (-40 to +140 °F)
II 2GD	Exde [ia] IIB T4	-20 to +60 °C (-4 to +140 °F)	-40 to +60 °C (-40 to +140 °F)
II 2GD	Exde [ia] IIC T4	-20 to +60 °C (-4 to +140 °F)	-40 to +60 °C (-40 to +140 °F)

International Hazardous Area IECEx

Directive/Standard	Rating	Standard Temperature	Low Temperature Option
IECEx	Exd [ia] IIB T4	-20 to +60 °C (-4 to +140 °F)	-40 to +60 °C (-40 to +140 °F)
IECEx	Exd [ia] IIC T4	-20 to +60 °C (-4 to +140 °F)	-40 to +60 °C (-40 to +140 °F)
IECEx	Exde [ia] IIB T4	-20 to +60 °C (-4 to +140 °F)	-40 to +60 °C (-40 to +140 °F)
IECEx	Exde [ia] IIC T4	-20 to +60 °C (-4 to +140 °F)	-40 to +60 °C (-40 to +140 °F)

Note: The Intrinsically Safe interface [ia] is an optional extra.

Standard Specifications

6.2 Hazardous Area Enclosures cont.

USA Hazardous Area – Factory Mutual Certified Explosionproof to NEC Article 500

Class	Division	Group	Standard Temperature	Low Temperature Option
I	1	C, D	-20 to +60 °C	-40 to +60 °C
II	1	E, F, G	(-4 to +140 °F)	(-40 to +140 °F)
I	1	B, C, D	-20 to +60 °C	-40 to +60 °C
II	1	E, F, G	(-4 to +140 °F)	(-40 to +140 °F)

Canadian Hazardous Area – Canadian Standards Association (CSA EP) to NEC Article 500

Class	Division	Group	Standard Temperature	Low Temperature Option
I	1	C, D	-20 to +60 °C	-40 to +60 °C
II	1	E, F, G	(-4 to +140 °F)	(-40 to +140 °F)
I	1	B, C, D	-20 to +60 °C	-40 to +60 °C
II	1	E, F, G	(-4 to +140 °F)	(-40 to +140 °F)

INMETRO

Directive / Standard Rating	Standard Temperature	Low Temperature Option
Ex d IIB T4 Gb IP6X	-20 to +60 °C (-4 to +140 °F)	-40 to +60 °C (-40 to +140 °F)
Ex de IIB T4 Gb IP6X	-20 to +60 °C (-4 to +140 °F)	-40 to +60 °C (-40 to +140 °F)
Ex d IIC T4 Gb IP6X	-20 to +60 °C (-4 to +140 °F)	-40 to +60 °C (-40 to +140 °F)
Ex de IIC T4 Gb IP6X	-20 to +60 °C (-4 to +140 °F)	-20 to +60 °C (-4 to +140 °F)

GOST

Directive / Standard Rating	Standard Temperature
1ExdIIBT4	-40 to +60 °C (-40 to +140 °F)
1ExdIICT4	-40 to +60 °C (-40 to +140 °F)
1ExdeIIBT4	-40 to +60 °C (-40 to +140 °F)
1ExdeIICT4	-40 to +60 °C (-40 to +140 °F)

Standard Specifications

7 Regulatory Standards

Compliance with the following European Economic Community Directives permits the CVA range of actuators to be CE marked under the provision of the Machinery Directive.

Directive	Applicable to	Reference
Electromagnetic compatibility (EMC)	Immunity to/emissions of electromagnetic energy	2004/108/EC by application of BS EN 61326-1:2006
Low Voltage (LV)	Electrical Safety	2006/95/EC by application of BS EN 601010-1:2001
Machinery*	Product Safety	Actuators follow the provision of the Machinery Directive (98/37/EC) as amended by 98/79/EC. The CVA must not be put into service until the equipment into which it is being incorporated has been declared to be in conformity with the provisions of the European Community Machinery Directive 98/37/EC and 98/79/EC*
Waste Electrical Equipment (WEE)	Exempt under the scope of the directive	

*Actuators are not classified as machines within the scope of the machinery directive. Contact Rotork for a copy of our Declaration of Conformity and Incorporation.

8 Paint Finish

The standard paint finish is RAL5010 (blue) polyester powder coated to Rotork specification RS237. Optional paint colours and finishes are available, please apply for more information.

Notes

Definition of T86:

ISA-75.25.01-2000 (R2006) - Test Procedure for Control Valve Response Measurement from Step Inputs. (Formerly ANSI/ISA-75.25.01-2000)

Defined as:

3.28 Step response time (T86):

The interval of time between initiation of an input signal step change and the moment that the response of a dynamic (*actuator and valve*) reaches 86.5% of its full steady state value. The step response time includes the dead time before the dynamic response.

T86b (*base response time*) is the greater T861 (*retract/open*) or 862 T862 (*extend/close*).

rotork®



www.rotork.com

A full listing of our worldwide sales and service network is available on our website.

Rotork plc
Brassmill Lane, Bath, UK
tel +44 (0)1225 733200
email mail@rotork.com

USA
Rotork Controls Inc.
tel +1 (585) 247 2304
email info@rotork.com

PUB042-001-00
Issue 02/15

As part of a process of on-going product development, Rotork reserves the right to amend and change specifications without prior notice. Published data may be subject to change. For the very latest version release, visit our website at www.rotork.com

The name Rotork is a registered trademark. Rotork recognises all registered trademarks. The Bluetooth® word mark and logos are registered trademarks owned by Bluetooth SIG, Inc. and any use of such marks by Rotork is under license. Published and produced in the UK by Rotork. POWIB0521